



**Geschirrspülmaschinen**

**Warewashers**

**Machines à laver la vaisselle**



**CS / CN / CP**

**ERSATZTEILE  
SPARE PARTS  
PIECES DETACHEES**

Ab Serien-Nummer:  
Starting from Serial No.:  
A partir du no. de série:

CN/CP	Protronic	- 86 68 00001 / DSN: CN-09-02
CN	Smartronic	- 86 67 00001 / DSN: CN-09-02
CS	Easytronic	- 8643 6001

REV. 11.10.2012

Die in diesem Katalog aufgeführten Elektroteile beziehen sich auf folgende Anschluss-Spannungen:  
 Electrical components listed in this catalogue are rated for the following supply voltages:  
 Les composants électriques énumérés dans ce catalogue sont prévus pour les tensions suivantes:



**400V / 50Hz / 3 / PE**

Bei nicht aufgeführten Anschluss-Spannungen bitte den, der Maschine beigelegten Schaltplan beachten.

For other voltages, refer to the wiring diagram shipped with the machine.

Pour d'autres tensions, se référer au schéma électrique envoyé avec la machine.

	<b>ERKLÄRUNG</b>	<b>LEGEND</b>	<b>LEGENDE</b>
<b>1</b>	Verschleißteile	Wearing parts	Pièces d'usure
<b>1</b>	Betriebswichtige Ersatzteile	Recommended spare parts	Pièces de rechange pour maintenance
<b>(L / R)</b>	Laufriichtung links / rechts	Operation direction left / right	Sens de marche gauche / droite
<b>(R / L)</b>	Laufriichtung rechts / links	Operation direction right / left	Sens de marche droite / gauche
<b>BSP</b>	Besteckspurbreite	Cutlery track width	Largeur de la piste des couverts

Inhalt	Kapitel
Hauben .....	01
E Vorwaschung .....	02
L Vorwaschung .....	03
S/A Vorwaschung .....	04
C Vorwaschung .....	05
AR/AN Waschung .....	06
ND Modul .....	07
Spülmodul .....	08
Trennmodul .....	09
Waschsystem .....	10
Erhitzer .....	11
Spülsystem .....	12
Füllsystem .....	13
Wärmerückgewinnung .....	14
Wärmepumpe .....	15
Transportsystem .....	16
Türen und Verkleidungen .....	17
Trocknung – gerade .....	18
Transportkurven .....	19
Dampfverrohrung .....	20
CAF Eckeinschub .....	21
Tischendschalter .....	22
Vorhänge .....	23

Content	Chapter
Hoods .....	01
E prewash .....	02
L prewash .....	03
S/A prewash .....	04
C prewash .....	05
AR/AN wash .....	06
ND Module .....	07
Rinse module .....	08
Disconnecting module .....	09
Wash system .....	10
Booster .....	11
Rinse system .....	12
Filling system .....	13
Heat recovery .....	14
Heat pump .....	15
Transport system .....	16
Doors and panels .....	17
Dryer – straight .....	18
Transport curves .....	19
Steam piping .....	20
CAF corner guiding .....	21
Table end switch .....	22
Curtains .....	23

<b>Sommaire</b>	<b>Chapitre</b>
Capots .....	01
E pré lavage .....	02
L pré lavage .....	03
S/A pré lavage .....	04
C pré lavage .....	05
AR/AN lavage .....	06
ND Module .....	07
Module de rinçage .....	08
Module de passage .....	09
Système de lavage .....	10
Chaudière .....	11
Système de rinçage .....	12
Système de remplissage .....	13
Récupération de la chaleur .....	14
Pompe à chaleur .....	15
Système de convoyage .....	16
Portes et panneaux .....	17
Séchage – droit .....	18
Convoyage d'angle.....	19
Tuyauterie vapeur.....	20
CAF guidage sur angle.....	21
Interrupteur fin-de-course de table.....	22
Rideaux .....	23



8 (800) 500-34-41  
www.platonservice.com



**PLATON** SERVICE

8 (800) 500-34-41

[www.platonservice.com](http://www.platonservice.com)

**CS / CN / CP**

**Hauben**

**Hoods**

**Capots**

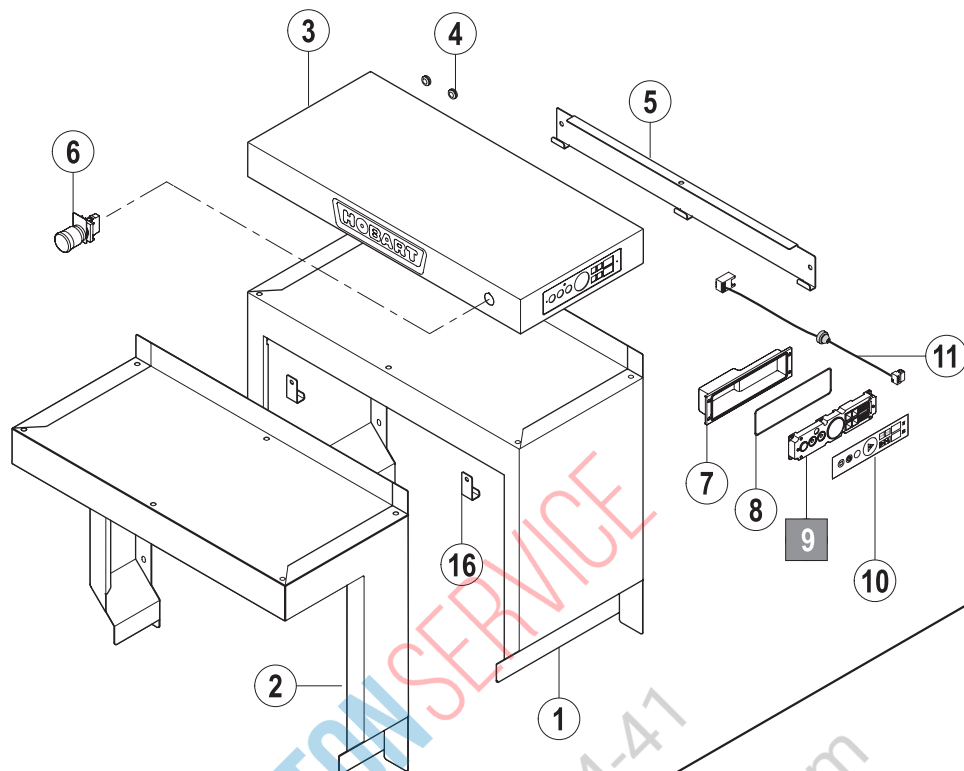

Zulauf  
 Loading section  
 Zone d'entrée



PLATON SERVICE  
 8 (800) 500-34-47  
 www.platonservice.com

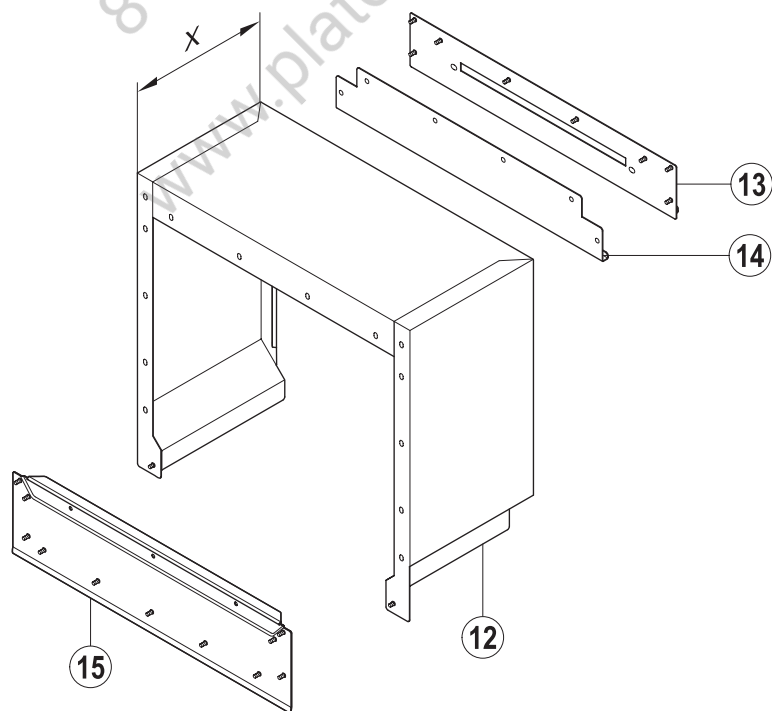

Auslauf  
 Unload section  
 Zone de déchargement



**A** Laufrichtung  
Working direction  
Sens de marche

**B** Maschinen-Grundtyp  
Basic machine  
Machine de base

**X** Länge  
Length  
Longueur

Pos.	A	B			X [mm]	Bemerkung / Remarks / Remarques
		CS	CN	CP		
01		---	01-291402-001	---		
02		---	01-291502-001	---		
03	L/R	---	01-291406-001	---		
	R/L	---	01-291406-002	---		
04		---	00-227748-001	---		
05		---	01-291538-002	---		
06		01-291707-001	=	=		
07		---	01-296387-001	---		
08		---	00-883805-001	---		
09		---	00-897540-001	---		
10		---	01-291845-001	---		
11		---	01-249757-001	---		
12		---	01-291404-001	=	300	
		01-291404-003	01-291404-002	01-291404-002	110	
13		01-291434-001	=	=		
14		01-291538-001	=	=		
15		01-291429-001	=	=		
16		---	01-291508-001	---		



PLATON SERVICE

8 (800) 500-34-47  
www.platonservice.com







**PLATON**SERVICE

8 (800) 500-34-41

[www.platonservice.com](http://www.platonservice.com)

**CS / CN / CP**

**E Vorwaschung**

**E prewash**

**E pré lavage**

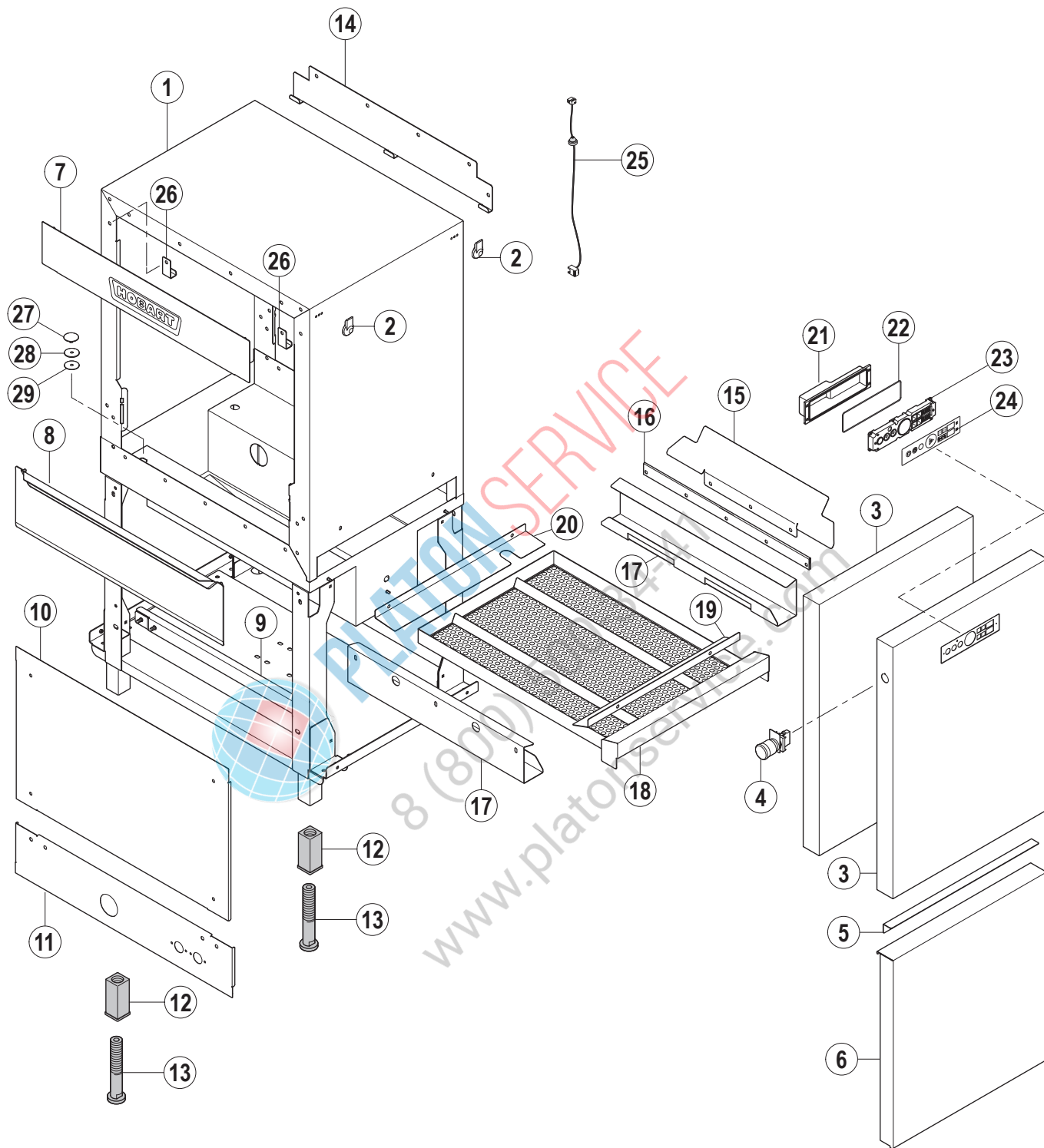



**A** Laufrichtung  
Working direction  
Sens de marche

**B** Maschinen-Grundtyp  
Basic machine  
Machine de base

**X** Länge  
Length  
Longueur

Pos.	A	B			X [mm]	Bemerkung / Remarks / Remarques
		CS	CN	CP		
01	L/R	01-291558-003	01-291558-001	01-291558-001		
	R/L	01-291558-004	01-291558-002	01-291558-002		
02		00-325037-001	00-325037-001	00-325037-001		
03	L/R	01-291488-006	01-291488-001	01-291488-005		
	R/L	01-291488-006	01-291488-002	01-291488-005		
04		01-291707-001	=	=		
05		00-896335-001	=	=		
06		01-291785-001	=	=		
07		01-291497-001	=	=		
08		01-291429-001	=	=		
09		01-291432-001	=	=		
10		01-291409-002	=	=		
11	L/R	01-291408-001	=	=		
	R/L	01-291408-002	=	=		
12		00-325008-001	=	=		
13		00-325007-001	=	=		
14		01-291538-001	=	=		
15		00-896430-003	=	=		
16		00-325155-003	=	=		
17		01-291783-001	=	=		
18		01-291782-001	=	=		ohne Magnet / without magnet / sans aimant
		---	01-291782-004	=		mit Magnet / with magnet / avec aimant
19		01-291784-001	=	=		
20	L/R	01-291784-002	=	=		
	R/L	01-291784-003	=	=		
21		---	01-296387-001	---		
22		---	00-883805-001	---		
23		---	00-897540-001	---		
24		---	01-291845-001	---		
25		---	01-249757-001	---		
26		01-291508-001	=	=		
27		00-869137-003	=	=		
28		00-168611-024	=	=		
29		00-696943-030	=	=		

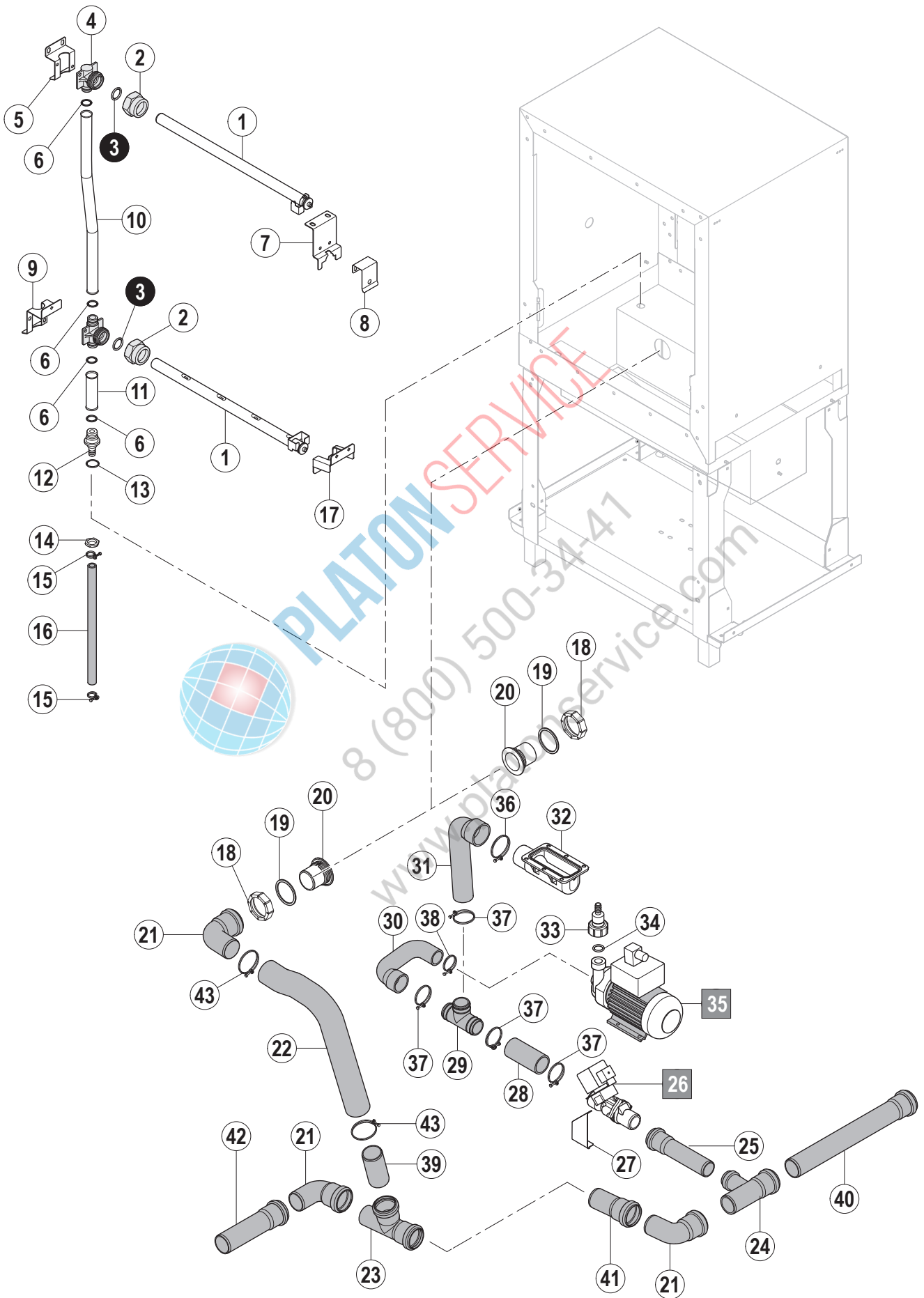

Pos.	A	B			X [mm]	Bemerkung / Remarks / Remarques
		CS	CN	CP		
01		01-291307-001	=	=		
02		00-885572-001	=	=		
03		00-884505-002	=	=		
04		01-245318-002	=	=		
05		01-291337-001	=	=		
06		01-245340-001	=	=		
07		01-291495-001	=	=		
08		01-245062-001	=	=		
09		01-291341-001	=	=		
10		01-245323-003	=	=		
11		01-291297-003	=	=		
12		01-245329-001	=	=		
13		01-245340-002	=	=		
14		00-172739-009	=	=		
15		00-323945-022	=	=		
16		01-245571-014	=	=		
17		01-291494-001	=	=		
18		01-245165-001	=	=		
19		01-245460-001	=	=		
20		01-245112-001	=	=		
21		00-230080-001	=	=		
22		01-291519-001	=	=		
23		00-230079-001	=	=		
24		00-323593-002	=	=		
25		00-325706-011	=	=		
26		00-774683-...	=	=		siehe Schaltplan / see wiring diagram / voir schéma de câblage
27		01-291686-001	=	=		
28		01-291525-002	=	=		
29		01-291562-001	=	=		
30		01-291691-001	=	=		
31		01-242108-002	=	=		
32		00-325529-001	=	=		
33		00-895735-001	=	=		
34		00-067500-072	=	=		
35		00-781237-...	=	=		siehe Schaltplan / see wiring diagram / voir schéma de câblage
36		00-323945-064	=	=		
37		00-323945-053	=	=		
38		00-323945-043	=	=		
39		00-325737-007	=	=		
40		00-229679-005	=	=		
41		00-229679-013	=	=		
42		00-600569-000	=	=		
43		00-323945-068	=	=		





**PLATON**SERVICE

8 (800) 500-34-41

[www.platonservice.com](http://www.platonservice.com)

**CS / CN / CP**

**L Vorwaschung**

**L prewash**

**L prélavage**

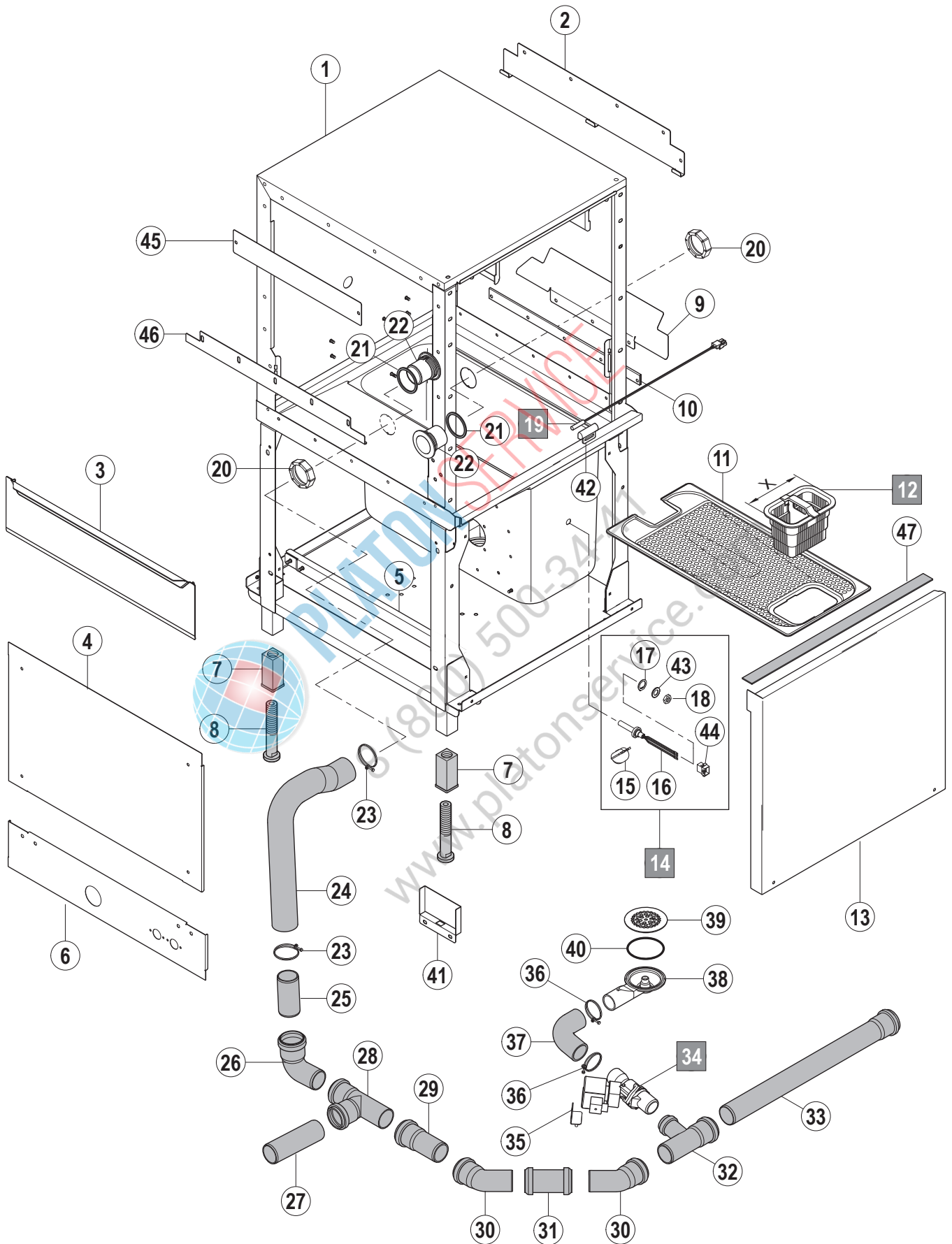



Pos.	A	B			X [mm]	Bemerkung / Remarks / Remarques
		CS	CN	CP		
01	L/R	---	01-291705-002	=		
	R/L	---	01-291705-001	=		
02		---	01-291538-001	=		
03		---	01-291429-001	=		
04		---	01-291409-001	=		ohne ASR / without ASR / sans ASR
		---	01-291409-006	=		mit ASR / with ASR / avec ASR
05		---	01-291432-001	=		
06	L/R	---	01-291408-001	=		
	R/L	---	01-291408-002	=		
07		---	00-325008-001	=		
08		---	00-325007-001	=		
09		---	00-896430-003	=		
10		---	00-325155-003	=		
11		---	01-291289-001	=		Mit / With / Avec 01-291515-001 / 01-245867-004
		---	01-291289-002	=		Mit / With / Avec 01-291515-002 / 01-245867-008
12		---	01-291515-001	=	176	Kunststoff / Plastic / Plastique
		---	01-291515-002	=	246	Kunststoff / Plastic / Plastique
		---	01-291515-004	=	246	Kunststoff mit Magnet / plastic with magnet / plastique avec aimant
		---	01-245867-004	=	176	Edelstahl / Stainless steel / Acier inoxydable
		---	01-245867-008	=	246	Edelstahl / Stainless steel / Acier inoxydable
	---	01-245867-010	=	246	Edelst. mit Magnet / stainl. steel with magnet / Acier inoxydable avec aimant	
13	L/R	---	01-291407-006	=		
	R/L	---	01-291407-007	=		
14		---	01-245621-002	=		
15		---	00-122674-000	=		
16		---	01-296000-001	=		
17		---	00-112467-000	=		
18		---	00-602476-000	=		
19		---	01-240288-001	=		
20		---	01-245165-001	=		
21		---	01-245460-001	=		
22		---	01-245112-001	=		
23		---	00-323945-064	=		
24		---	01-291519-001	=		
25		---	00-325737-007	=		
26		---	00-230080-001	=		
27		---	00-325737-004	=		
28		---	00-230079-001	=		
29		---	00-229679-013	=		
30		---	00-377340-001	=		
31		---	00-229680-001	=		
32		---	00-323593-002	=		
33		---	00-600571-000	=		
34		---	00-774683-...	=		siehe Schaltplan / see wiring diagram / voir schéma de câblage
35		---	01-291684-002	=		
36		---	00-323945-053	=		
37		---	01-291527-002	=		
38		---	01-245109-001	=		
39		---	01-245107-001	=		

**A** Laufrichtung  
Working direction  
Sens de marche

**B** Maschinen-Grundtyp  
Basic machine  
Machine de base

**X** Länge  
Length  
Longueur

Pos.	A	B			X [mm]	Bemerkung / Remarks / Remarques
		CS	CN	CP		
40		---	01-245340-004	=		
41		---	01-291982-001	=		
42		---	00-883838-001	=		
43		---	00-168611-021	=		
44		---	00-174994-013	---		
45		---	01-291197-004	---		
46		---	00-896394-001	=		
47		---	01-296451-003	=		



PLATON SERVICE

8 (800) 500-34-47

www.platonservice.com



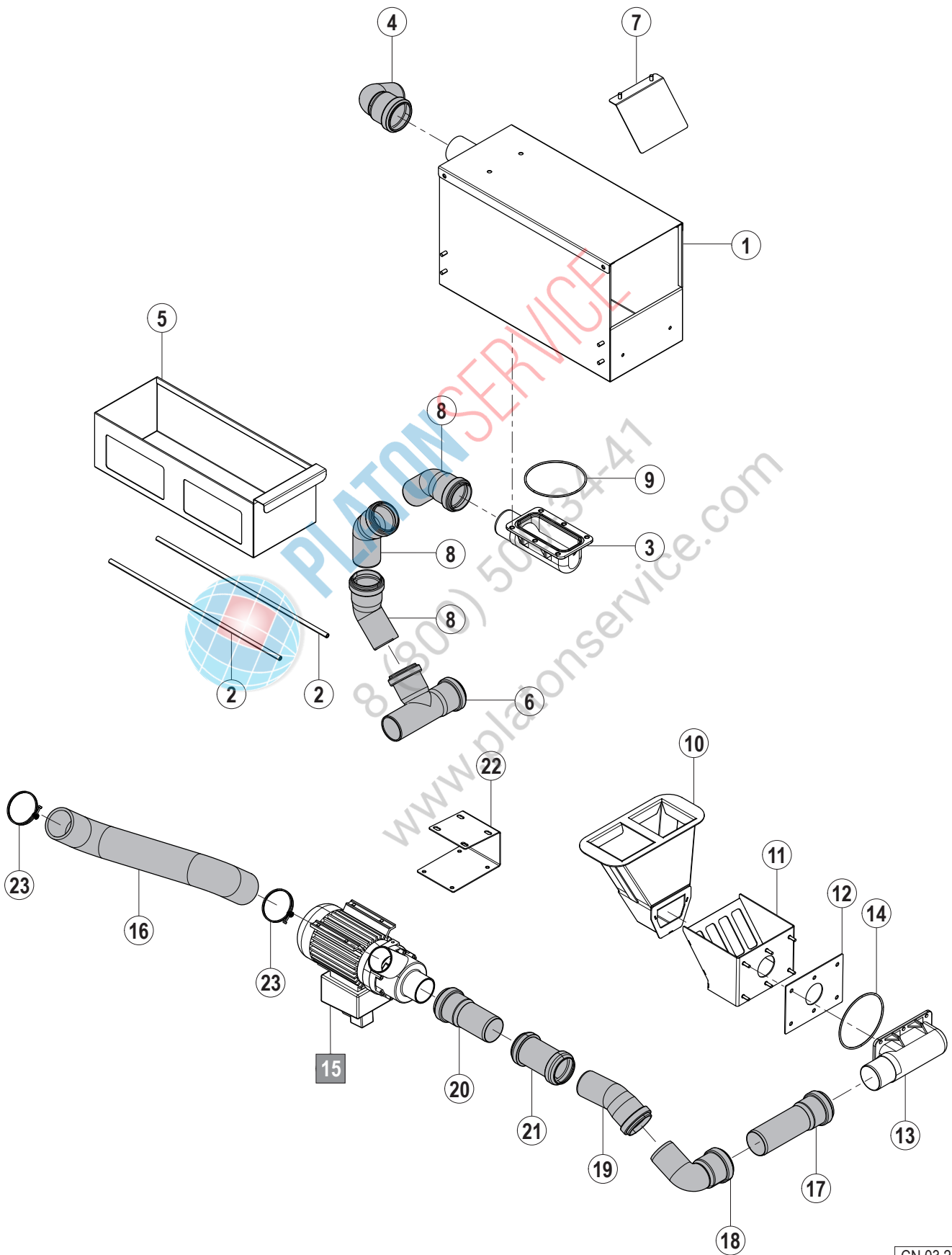

Pos.	A	B			X [mm]	Bemerkung / Remarks / Remarques
		CS	CN	CP		
01		---	01-296869-001	=		
02		---	01-245146-006	=		
03		---	00-325529-001	=		
04		---	00-230080-001	=		
05		---	01-296866-001	=		
06		---	00-230079-001	=		
07		---	01-518204-001	=		
08		---	00-377340-001	=		
09		---	00-276903-035	=		
10		---	01-297196-002	=		ohne Magnet / without magnet / sans aimant
		---	01-297196-005	=		mit Magnet / with magnet / avec aimant
11		---	01-297199-003	=		
12		---	01-297201-002	=		
13		---	00-325529-001	=		
14		---	00-276903-035	=		
15		---	01-297295-001	=		
16		---	01-296864-001	=		
17		---	00-229679-036	=		
18		---	00-230080-001	=		
19		---	00-377339-001	=		
20		---	00-229679-013	=		
21		---	00-229680-001	=		
22		---	01-296871-001	=		
23		---	00-323945-068	=		



PLATON SERVICE  
8 (800) 500-34-47  
www.platonservice.com





**PLATON**SERVICE

8 (800) 500-34-41

[www.platonservice.com](http://www.platonservice.com)

**CS / CN / CP**

**S/A Vorwaschung**

**S/A prewash**

**S/A prélavage**

04.1

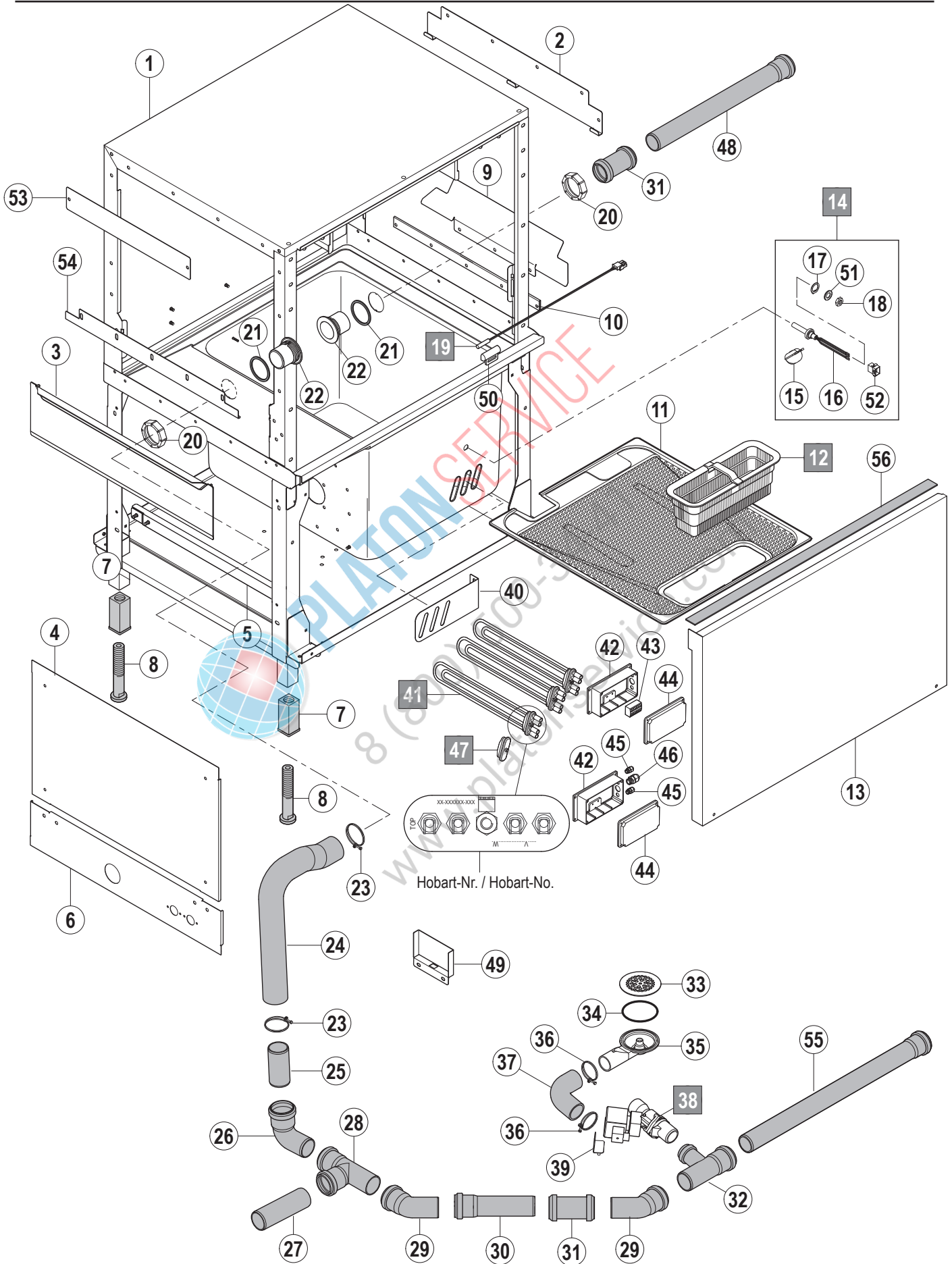

CN 04.1a



Pos.	A	B			X [mm]	Bemerkung / Remarks / Remarques
		CS	CN	CP		
01	L/R	---	01-291706-001	=		
	R/L	---	01-291706-002	=		
02		---	01-291538-001	=		
03		---	01-291429-001	=		
04		---	01-291409-001	=	ohne ASR / without ASR / sans ASR	
		---	01-291409-007	=	mit ASR / with ASR / avec ASR	
05		---	01-291432-001	=		
06	L/R	---	01-291408-001	=		
	R/L	---	01-291408-002	=		
07		---	00-325008-001	=		
08		---	00-325007-001	=		
09		---	00-896430-003	=		
10		---	00-325155-003	=		
11	L/R	---	01-245047-006	=		
	R/L	---	01-245047-005	=		
12		---	01-245170-010	=	Kunststoff / Plastic / Plastique	
		---	01-245170-011	=	Kunststoff mit Magnet / plastic with magnet / plastique avec aimant	
		---	01-245867-003	=	Edelstahl / Stainless steel / Acier inoxydable	
		---	01-245867-007	=	Edelst. mit Magnet / stainl. steel with magnet / Acier inoxydable avec aimant	
13	L/R	---	01-291407-004	=	nur / only / seulement <b>S-Modul</b>	
	R/L	---	01-291407-005	=	nur / only / seulement <b>S-Modul</b>	
		---	01-291407-011	=	nur / only / seulement <b>A-Modul</b>	
14		---	01-245621-002	=		
15		---	00-122674-000	=		
16		---	01-296000-001	=		
17		---	00-112467-000	=		
18		---	00-602476-000	=		
19		---	01-240288-001	=		
20		---	01-245165-001	=		
21		---	01-245460-001	=		
22		---	01-245112-001	=		
23		---	00-323945-064	=		
24		---	01-291519-001	=		
25		---	00-325737-007	=		
26		---	00-230080-001	=		
27		---	00-325737-004	=		
28		---	00-230079-001	=		
29		---	00-377340-001	=		
30		---	00-600569-000	=		
31		---	00-229680-001	=		
32		---	00-323593-002	=		
33		---	01-245107-001	=		
34		---	01-245340-004	=		
35		---	01-245109-001	=		
36		---	00-325945-053	=		
37		---	01-291527-002	=		
38		---	00-774683-...	=	siehe Schaltplan / see wiring diagram / voir schéma de câblage	
39		---	01-291684-002	=		
40		---	01-245372-002	=		

04.1

Pos.	A	B			X [mm]	Bemerkung / Remarks / Remarques
		CS	CN	CP		
41		---	00-324637-...	=		siehe Schaltplan / see wiring diagram / voir schéma de câblage
42		---	01-245373-001	=		
43		---	00-325025-000	=		
44		---	01-245374-001	=		
45		---	00-695661-001	=		
46		---	00-695661-003	=		
47		---	00-774808-001	=		
48		---	00-229679-025	=		
49		---	01-291982-001	=		
50		---	00-883838-001	=		
51		---	00-168611-021	=		
52		---	00-174994-013	---		
53		---	01-291197-004	---		
54		---	00-896394-001	=		nur S-Modul / only S-Module / seulement S-Module
55		---	00-229679-040	=		
56		---	01-296451-002	=		



PLATON SERVICE  
8 (800) 500-34-47  
www.platonservice.com



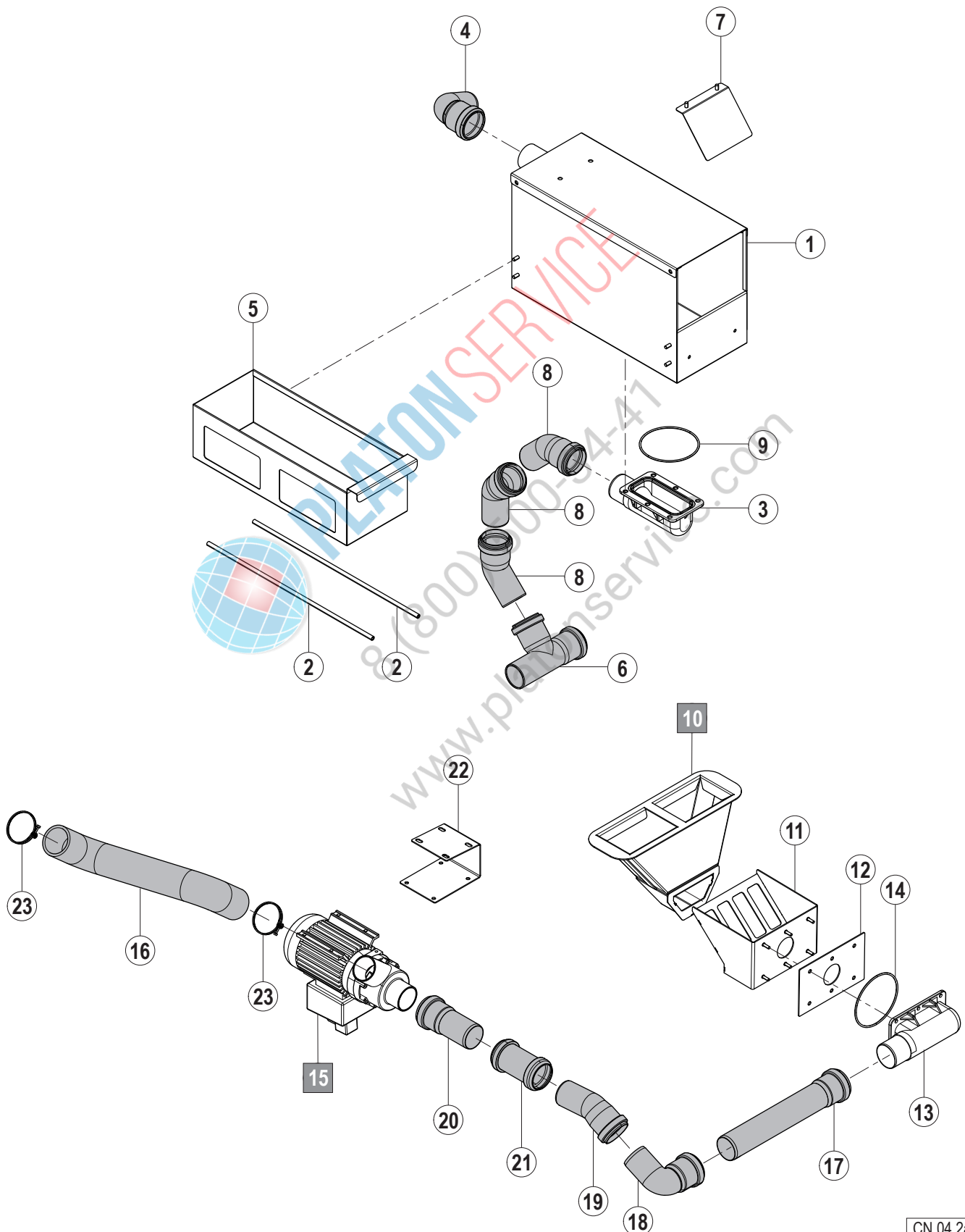

Pos.	A	B			X [mm]	Bemerkung / Remarks / Remarques
		CS	CN	CP		
01		---	01-296869-001	=		
02		---	01-245146-006	=		
03		---	00-325529-001	=		
04		---	00-230080-001	=		
05		---	01-296866-001	=		
06		---	00-230079-001	=		
07		---	01-518204-001	=		
08		---	00-377340-001	=		
09		---	00-276903-035	=		
10		---	01-297196-001	=		ohne Magnet / without magnet / sans aimant
		---	01-297196-004	=		mit Magnet / with magnet / avec aimant
11		---	01-297199-001	=		
12		---	01-297201-001	=		
13		---	00-325529-001	=		
14		---	00-276903-035	=		
15		---	01-297295-001	=		
16		---	01-296864-001	=		
17		---	00-229679-029	=		
18		---	00-230080-001	=		
19		---	00-377339-001	=		
20		---	00-229679-013	=		
21		---	00-229680-001	=		
22		---	01-296871-001	=		
23		---	00-323945-068	=		



PLATON SERVICE  
8 (800) 500-34-47  
www.platonservice.com





**PLATON** SERVICE

8 (800) 500-34-41

[www.platonservice.com](http://www.platonservice.com)

**CS / CN / CP**

**C Vorwaschung**

**C prewash**

**C prélavage**

05.1

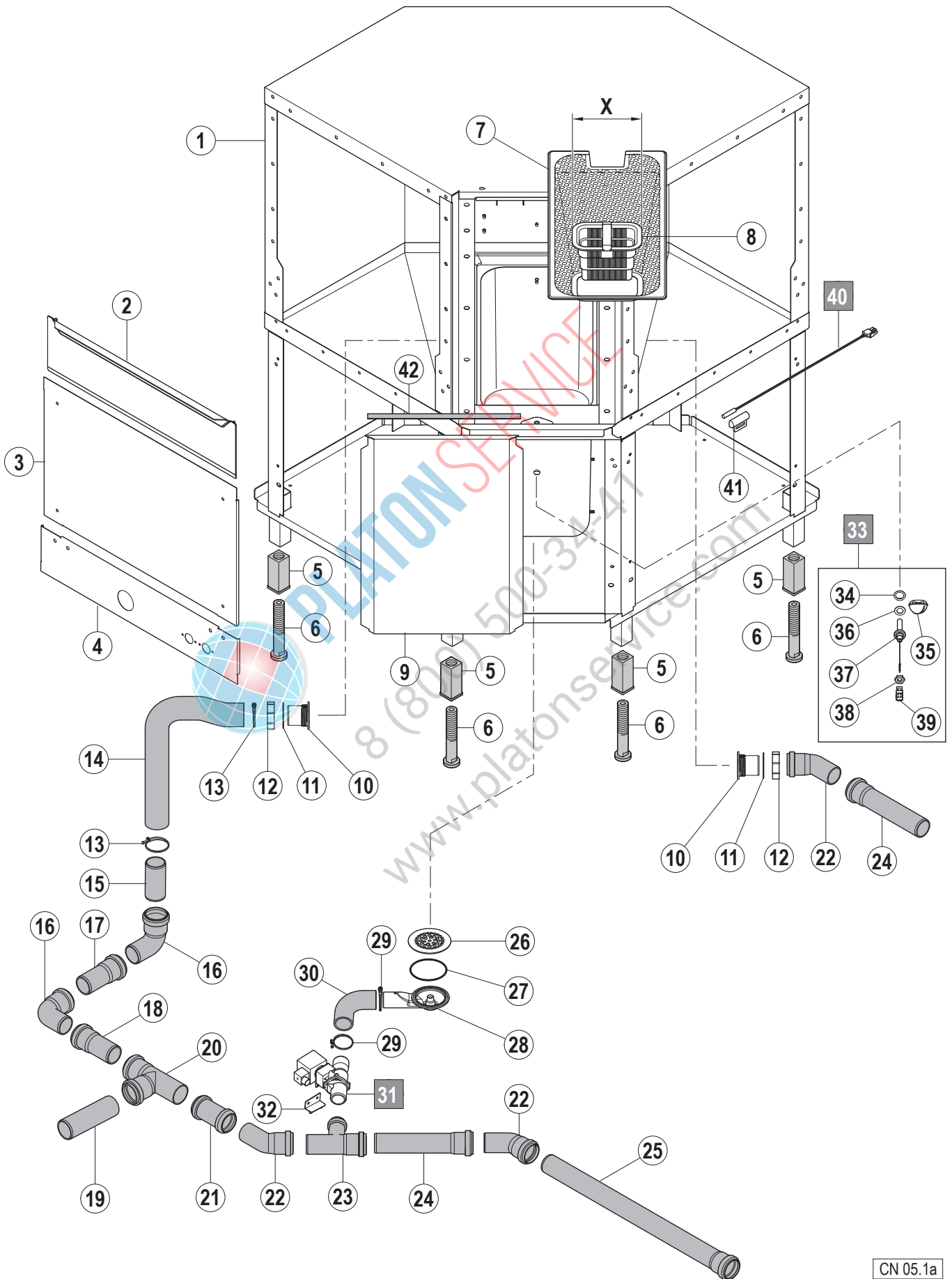

CN 05.1a



Pos.	A	B			X [mm]	Bemerkung / Remarks / Remarques
		CS	CN	CP		
01	L/R	---	01-291999-001	=		
	R/L	---	01-291999-002	=		
02		---	01-291429-001	=		
03		---	01-291409-001	=		ohne ASR / without ASR / sans ASR
	L/R	---	01-291409-006	=		mit ASR / with ASR / avec ASR
	R/L	---	01-291409-007	=		mit ASR / with ASR / avec ASR
04	L/R	---	01-291408-001	=		
	R/L	---	01-291408-002	=		
05		---	00-325008-001	=		
06		---	00-325007-001	=		
07		---	01-291289-001	=		Mit / With / Avec 01-291515-001 / 01-245867-004
		---	01-291298-002	=		Mit / With / Avec 01-291515-002 / 01-245867-005
08		---	01-291515-001	=	176	Kunststoff / Plastic / Plastique
		---	01-291515-002	=	246	Kunststoff / Plastic / Plastique
		---	01-291515-004	=	246	Kunststoff mit Magnet / plastic with magnet / plastique avec aimant
		---	01-245867-004	=	176	Edelstahl / Stainless steel / Acier inoxydable
		---	01-245867-008	=	246	Edelstahl / Stainless steel / Acier inoxydable
		---	01-245867-010	=	246	Edelst. mit Magnet / stainl. steel with magnet / Acier inoxydable avec aimant
09	L/R	---	01-296137-001	=		
	R/L	---	01-296137-002	=		
10		---	01-245112-001	=		
11		---	01-245460-001	=		
12		---	01-245265-001	=		
13		---	00-323945-064	=		
14		---	01-291519-001	=		
15		---	00-325737-001	=		
16		---	00-230080-001	=		
17		---	00-229679-013	=		
18		---	00-229679-012	=		
19		---	00-325737-004	=		
20		---	00-230079-001	=		
21		---	00-229680-001	=		
22		---	00-377340-001	=		
23		---	00-323593-002	=		
24		---	00-229679-024	=		
25		---	00-229679-005	=		
26		---	01-245107-001	=		
27		---	01-245340-004	=		
28		---	01-245109-001	=		
29		---	00-323945-053	=		
30		---	01-291527-002	=		
31		---	00-774683-...	=		siehe Schaltplan / see wiring diagram / voir schéma de câblage
32		---	01-291684-002	=		
33		---	01-245621-002	=		
34		---	00-112467-000	=		
35		---	00-112674-000	=		
36		---	00-168611-021	=		
37		---	01-296000-001	=		
38		---	00-602476-000	=		

05.1

Pos.	A	B			X [mm]	Bemerkung / Remarks / Remarques
		CS	CN	CP		
39		---	00-174994-013	=		
40		---	01-240288-001	=		
41		---	00-883838-001	=		
42		---	01-296451-003	=		



PLATON SERVICE  
8 (800) 500-34-47  
www.platonservice.com



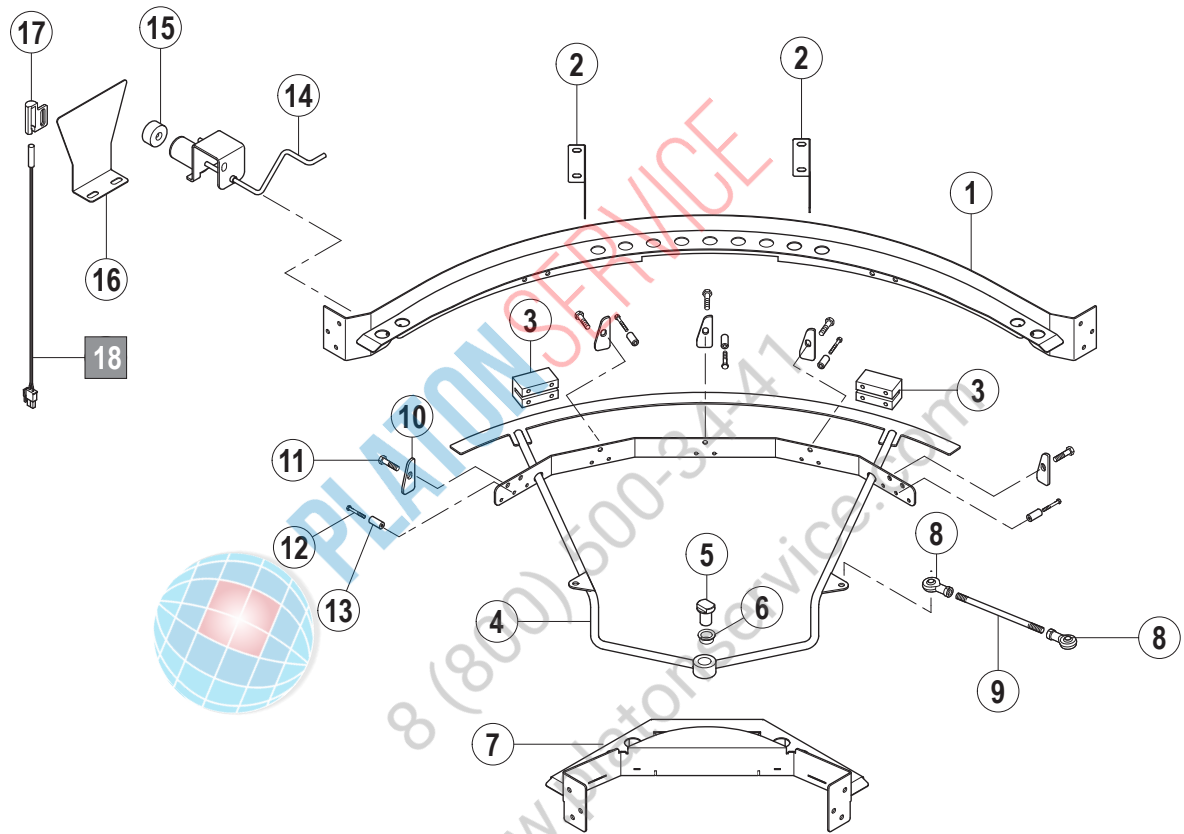

Pos.	A	B			X [mm]	Bemerkung / Remarks / Remarques
		CS	CN	CP		
01		---	01-296139-001	=		
02		---	01-296055-001	=		
03		---	01-296049-001	=		
04		---	01-296059-001	=		
05		---	00-734988-001	=		
06		---	00-298963-012	=		
07		---	01-296138-001	=		
08		---	00-609067-000	=		
09		---	00-884128-003	=		
10		---	00-897777-002	=		
11		---	00-609313-000	=		
12		---	00-602643-000	=		
13		---	00-380528-037	=		
14	L/R	---	01-242189-001	=		
	R/L	---	01-242189-002	=		
15		---	00-774714-001	=		
16		---	01-291513-002	=		
17		---	01-240288-001	=		
18		---	01-240288-001	=		

05.2



PLATON SERVICE  
8 (800) 500-34-47  
www.platonservice.com



Pos.	A	B			X [mm]	Bemerkung / Remarks / Remarques
		CS	CN	CP		
01		---	01-296154-001	=		ohne Isolierung / without insulation / sans isolation
		---	01-296154-002	=		mit Isolierung / with insulation / avec isolation
02		---	01-291317-004	=		ohne Isolierung / without insulation / sans isolation
		---	01-291711-004	=		mit Isolierung / with insulation / avec isolation
03		---	01-296116-001	=		ohne Isolierung / without insulation / sans isolation
		---	01-291711-006	=		mit Isolierung / with insulation / avec isolation
04		---	01-296-137-001	=		
05		---	01-245279-003	=		
06		---	01-296112-001	=		
07		---	01-245281-001	=		
08		---	01-245278-008	=		
09		---	01-291426-001	=		
10		---	01-245126-003	=		
11		---	00-325064-008	=		

05.3



PLATON SERVICE  
8 (800) 500-34-47  
www.platonservice.com

05.4

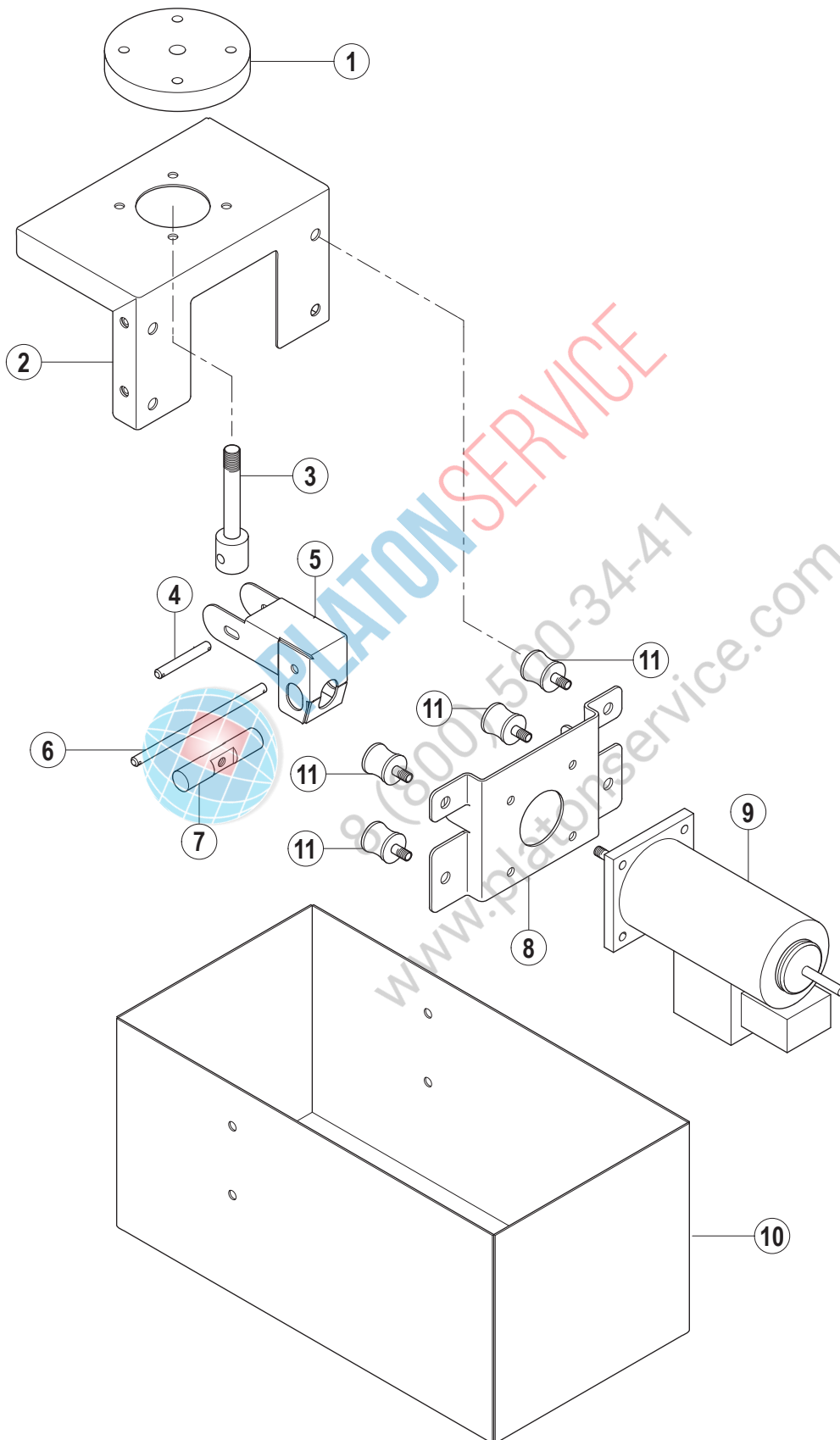



Pos.	A	B			X [mm]	Bemerkung / Remarks / Remarques
		CS	CN	CP		
01		---	00-887920-001	=		
02		---	00-887936-001	=		
03		---	00-887921-001	=		
04		---	00-380061-002	=		
05		---	00-868469-001	=		
06		---	00-380061-004	=		
07		---	00-693478-002	=		
08		---	00-868366-001	=		
09		---	00-696845-001	=		
10		---	00-897661-001	=		
11		---	00-696851-001	=		

05.4



PLATON SERVICE  
8 (800) 500-34-47  
www.platonservice.com





**PLATON** SERVICE

8 (800) 500-34-41

[www.platonservice.com](http://www.platonservice.com)

**CS / CN / CP**

**AR/AN Waschung**

**AR/AN wash**

**AR/AN lavage**

06.1

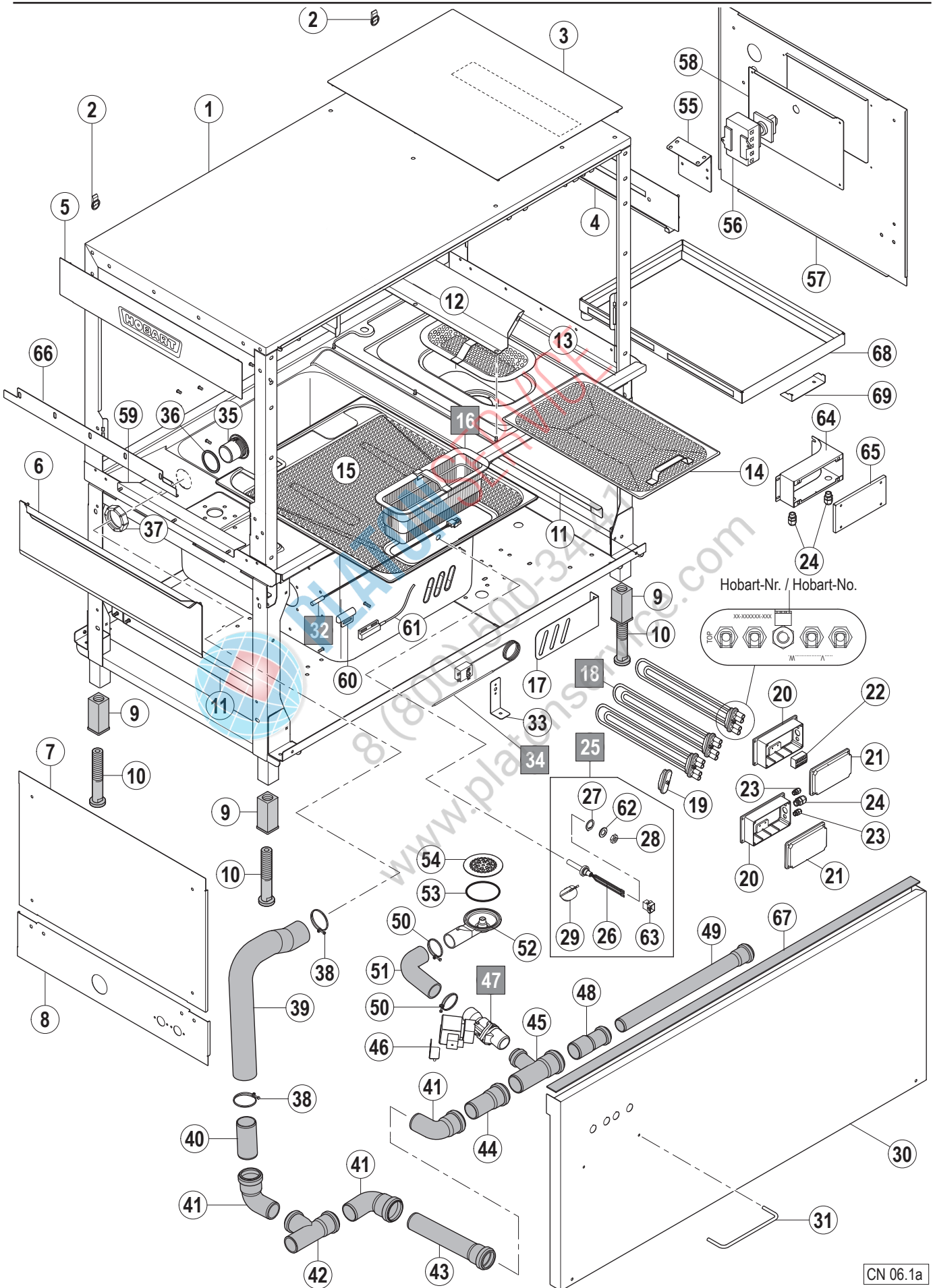

Hobart-Nr. / Hobart-No.

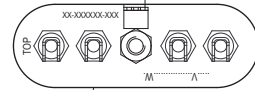

CN 06.1a

Pos.	A	B			X [mm]	Bemerkung / Remarks / Remarques
		CS	CN	CP		
01	L/R	01-245399-005	01-245399-001	01-245399-003		
	R/L	01-245399-006	01-245399-002	01-245399-004		
02		00-325037-001	---	---		
03		01-291799-001	---	---		
04		01-291434-001	=	=		
05		01-291497-001	---	---		
06		01-291429-001	=	=		
07		01-291409-001	=	=		
08	L/R	01-291408-001	=	=		
	R/L	01-291408-002	=	=		
09		00-325008-001	=	=		
10		00-325007-001	=	=		
11		01-291432-001	=	=		
12		01-245042-001	=	=		
13		00-325074-001	=	---		ohne Magnet / without magnet / sans aimant
		---	00-325074-002	---		mit Magnet / with magnet / avec aimant
14		---	---	01-245118-010		ohne Magnet / without magnet / sans aimant
		---	---	01-518207-003		mit Magnet / with magnet / avec aimant
15	L/R	01-245047-006	=	=		
	R/L	01-245047-005	=	=		
16		01-245170-010	=	=		Kunststoff / Plastic / Plastique
		---	01-245170-011	=		Kunststoff mit Magnet / plastic with magnet / plastique avec aimant
		01-245867-003	=	=		Edelstahl / Stainless steel / Acier inoxydable
		---	01-245867-007	=		Edelst. mit Magnet / stainl. steel with magnet / Acier inoxydable avec aimant
17		01-245372-002	=	=		
18		00-324637-...	=	=		siehe Schaltplan / see wiring diagram / voir schéma de câblage
19		00-774808-001	=	=		
20		---	01-245373-001	=		
21		---	01-245374-001	=		
22		---	00-325025-000	=		
23		---	00-695661-001	=		
24		---	00-695661-003	=		
25		01-245621-003	01-245621-002	=		
26		00-226282-012	01-296000-001	=		
27		00-112467-000	=	=		
28		00-602476-000	=	=		
29		00-122674-000	=	=		
30	L/R	01-291787-001	01-291787-005	01-291407-010		mit Vorwaschung / with prewash / avec pré lavage
	R/L	01-291787-002	01-291787-006	01-291407-010		mit Vorwaschung / with prewash / avec pré lavage
		---	01-291787-004	---		ohne Vorwaschung / without prewash / sans pré lavage
31		00-895734-001	---	---		
32		---	01-240288-001	=		
33		00-895758-001	---	---		
34		00-226505-...	---	---		
35		01-245112-001	=	=		
36		01-245460-001	=	=		
37		01-245165-001	=	=		
38		00-323945-064	=	=		
39		01-291519-001	=	=		

Pos.	A	B			X [mm]	Bemerkung / Remarks / Remarques
		CS	CN	CP		
40		00-325737-007	=	=		
41		00-230080-001	=	=		
42		00-230079-001	=	=		
43		00-229679-006	=	=		
44		00-229679-013	=	=		
45		00-323593-002	=	=		
46		01-291684-001	=	=		
47		00-774683-...	=	=		siehe Schaltplan / see wiring diagram / voir schéma de câblage
48		00-325708-001	=	=		
49		00-325706-017	=	=		
50		00-323945-053	=	=		
51		01-291527-001	=	=		
52		01-245109-001	=	=		
53		01-245340-004	=	=		
54		01-245107-001	=	=		
55		01-291425-001	=	---		
56		00-785574-...	=	---		siehe Schaltplan / see wiring diagram / voir schéma de câblage
57	L/R	01-296274-001	=	---		
	R/L	01-296274-002	=	---		
58		01-291427-001	=	---		
59		00-895737-001	---	---		
60		---	00-883838-001	---		
61		00-229517-000	---	---		
62		---	00-168611-021	=		
63		---	00-174994-013	---		
64	L/R	---	---	01-245657-001		
	R/L	---	---	01-245657-002		
65		---	---	01-296584-002		
66		00-896394-001	=	=		
67		01-296451-001	=	=		
68		---	---	01-292020-005		mit <b>SENSOTRONIC</b> / with <b>SENSOTRONIC</b> / avec <b>SENSOTRONIC</b>
69		---	---	01-245968-003		mit <b>SENSOTRONIC</b> / with <b>SENSOTRONIC</b> / avec <b>SENSOTRONIC</b>



06.2

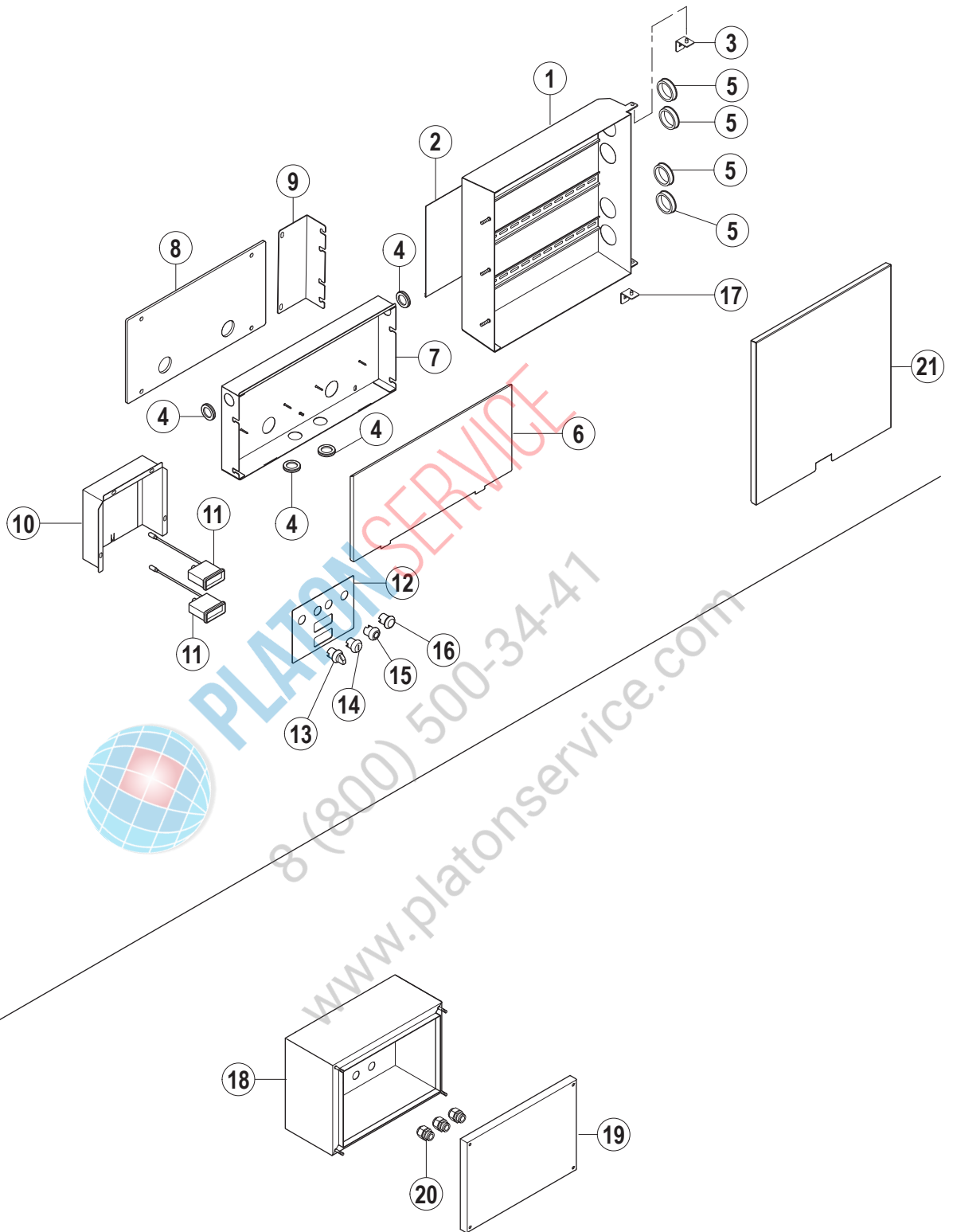

CN 06.2a



Pos.	A	B			X [mm]	Bemerkung / Remarks / Remarques
		CS	CN	CP		
01	L/R	01-518293-001	=	---		
	R/L	01-518293-002	=	---		
02		00-374384-000	=	---		
03		01-245228-002	=	---		
04		00-785565-005	=	---		
05		00-886756-001	=	---		
06		00-895732-001	=	---		
07		01-291424-001	=	---		
08		01-291499-001	=	---		
09		01-291786-001	---	---		
10		00-899256-001	---	---		
11		00-228720-003	---	---		
12		01-291809-001	---	---		ohne / without / sans Pos.11
		01-291809-002	---	---		mit / with / avec Pos.11
13		00-8870015-61	---	---		
14		00-887015-033	---	---		
15		00-887015-021	---	---		
16		00-887015-047	---	---		
17		01-245228-003	=	---		
18		=	01-296478-001	=		
19		=	01-296485-001	=		
20		=	00-695661-003	=		
21		01-296475-001	=	---		

06.2



PLATON SERVICE  
8 (800) 500-34-47  
www.platonservice.com



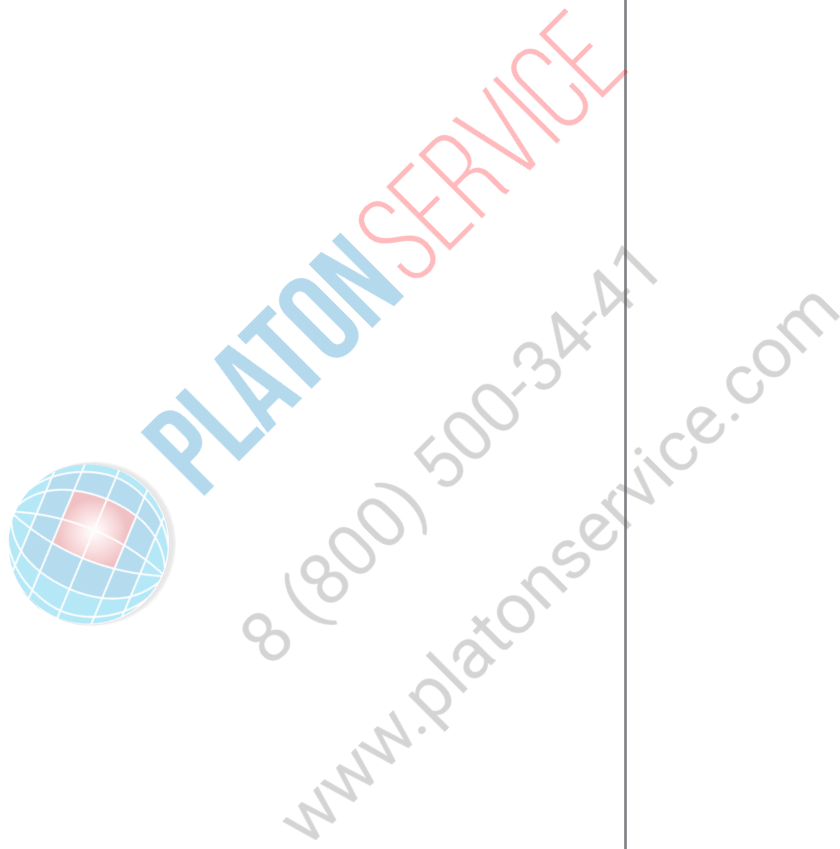

**CS / CN / CP**

**ND Modul**

**ND Module**

**ND Module**

07.1

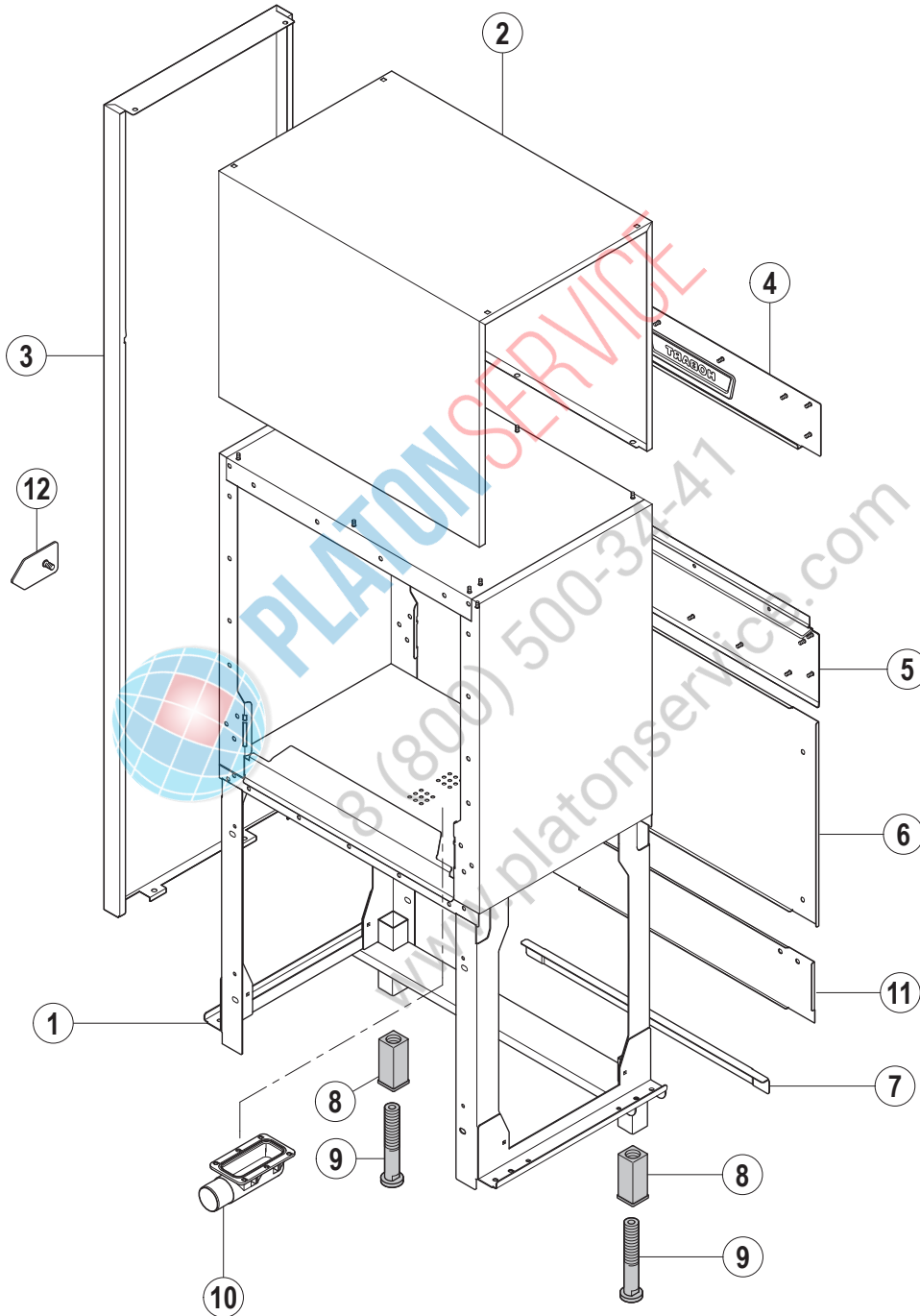

CN 07.1a

Pos.	A	B			X [mm]	Bemerkung / Remarks / Remarques
		CS	CN	CP		
01		---	01-291518-002	=		
02		---	01-291673-001	=		
03		---	01-291466-003	=		
04		---	01-291497-001	=		
05		---	01-291429-002	=		
06		---	01-291419-014	=		
07		---	01-291432-001	=		
08		---	00-325008-001	=		
09		---	00-325007-001	=		
10		---	00-325529-001	=		
11		---	01-296552-001	=		
12		---	01-296621-001	=		

07.1



PLATON SERVICE

8 (800) 500-34-41

www.platonservice.com

07.2

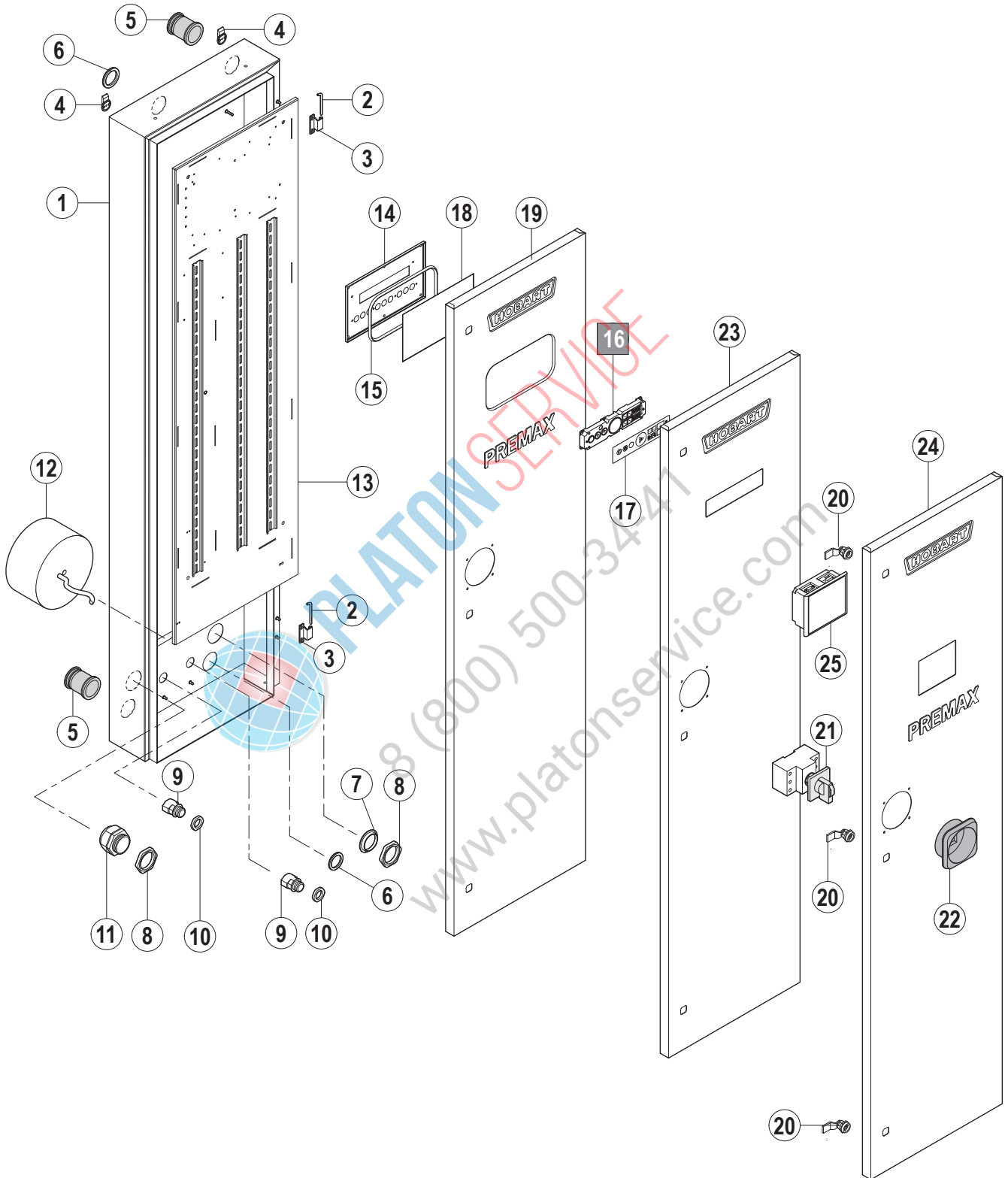

Pos.	A	B			X [mm]	Bemerkung / Remarks / Remarques
		CS	CN	CP		
01		---	01-291469-002	=		
02		---	00-325086-013	=		
03		---	00-325086-011	=		
04		---	00-325037-001	=		
05		---	00-325186-001	=		
06		---	00-325655-001	=		
07		---	00-695666-007	=		
08		---	00-695664-007	=		
09		---	00-774797-002	=		
10		---	00-695664-004	=		
11		---	00-695661-007	=		
12		---	00-774783-...	=		siehe Schaltplan / see wiring diagram / voir schéma de câblage
13		---	00-868499-003	=		
14		---	01-245672-001	=		
15		---	00-325554-004	=		
16		---	00-897540-002	---		
17		---	01-291845-001	---		
18		---	01-245674-002	=		
19		---	01-291472-001	01-291472-002		
20		---	00-229518-001	=		
21		---	00-301773-...	=		siehe Schaltplan / see wiring diagram / voir schéma de câblage
22		---	00-734115-002	00-734115-003		
23		---	01-291472-003	---		
24		---	01-291472-005	01-291472-004		
25		---	00-887104-002	00-887104-001		

07.2

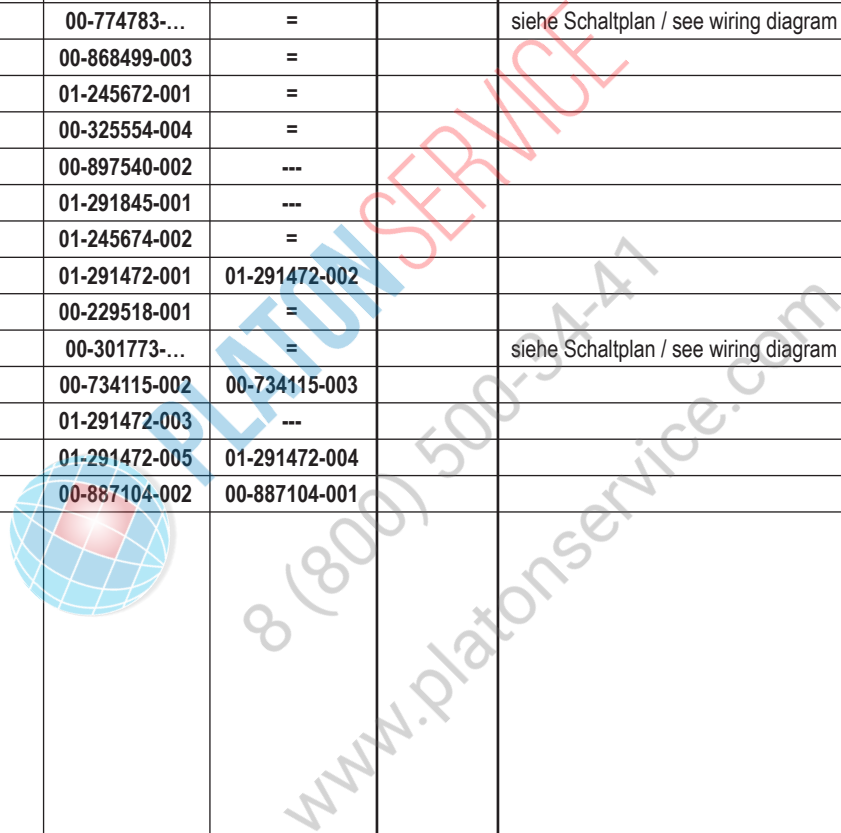







**PLATON**SERVICE

8 (800) 500-34-41

[www.platonservice.com](http://www.platonservice.com)

**CS / CN / CP**

**Spülmodul**

**Rinse module**

**Module de rinçage**



Pos.	A	B			X [mm]	Bemerkung / Remarks / Remarques
		CS	CN	CP		
01	L/R	---	01-291880-001	01-291880-003		
	R/L		01-291880-002	01-291880-004		
02		---	00-325155-003	=		
03		---	01-245279-002	=		
04		---	---	01-245118-010		ohne Magnet / without magnet / sans aimant
		---	---	01-518207-003		mit Magnet / with magnet / avec aimant
05		---	00-868460-001	---		ohne Magnet / without magnet / sans aimant
		---	00-868460-002	---		mit Magnet / with magnet / avec aimant
06		---	01-291434-001	=		
07		---	01-291425-002	---		
08		---	00-785574-...	---		siehe Schaltplan / see wiring diagram / voir schéma de câblage
09		---	01-291427-001	---		
10	L/R	---	01-291419-001	---		
	R/L		01-291419-002	---		
11		---	01-291432-011	=		
12		---	---	01-245655-002		
13		---	---	01-245656-004		
14	L/R	---	01-291407-007	01-291407-008		
	R/L		01-291407-006	01-291407-008		
15		---	00-325008-001	=		
16		---	00-325007-001	=		
17		---	00-229446-003	=		
18		---	00-168611-011	=		
19		---	00-172739-002	=		
20		---	00-323945-033	=		
21		---	00-898242-003	=		
22		---	00-325529-001	=		
23		---	01-240288-001	=		
24		---	00-883838-001	=		
25		---	---	01-292020-006		mit SENSOTRONIC / with SENSOTRONIC / avec SENSOTRONIC
26		---	---	01-245968-001		mit SENSOTRONIC / with SENSOTRONIC / avec SENSOTRONIC
27		---	00-226973-006	=		
28		---	01-245373-001	=		
29		---	01-245374-001	=		

08.2

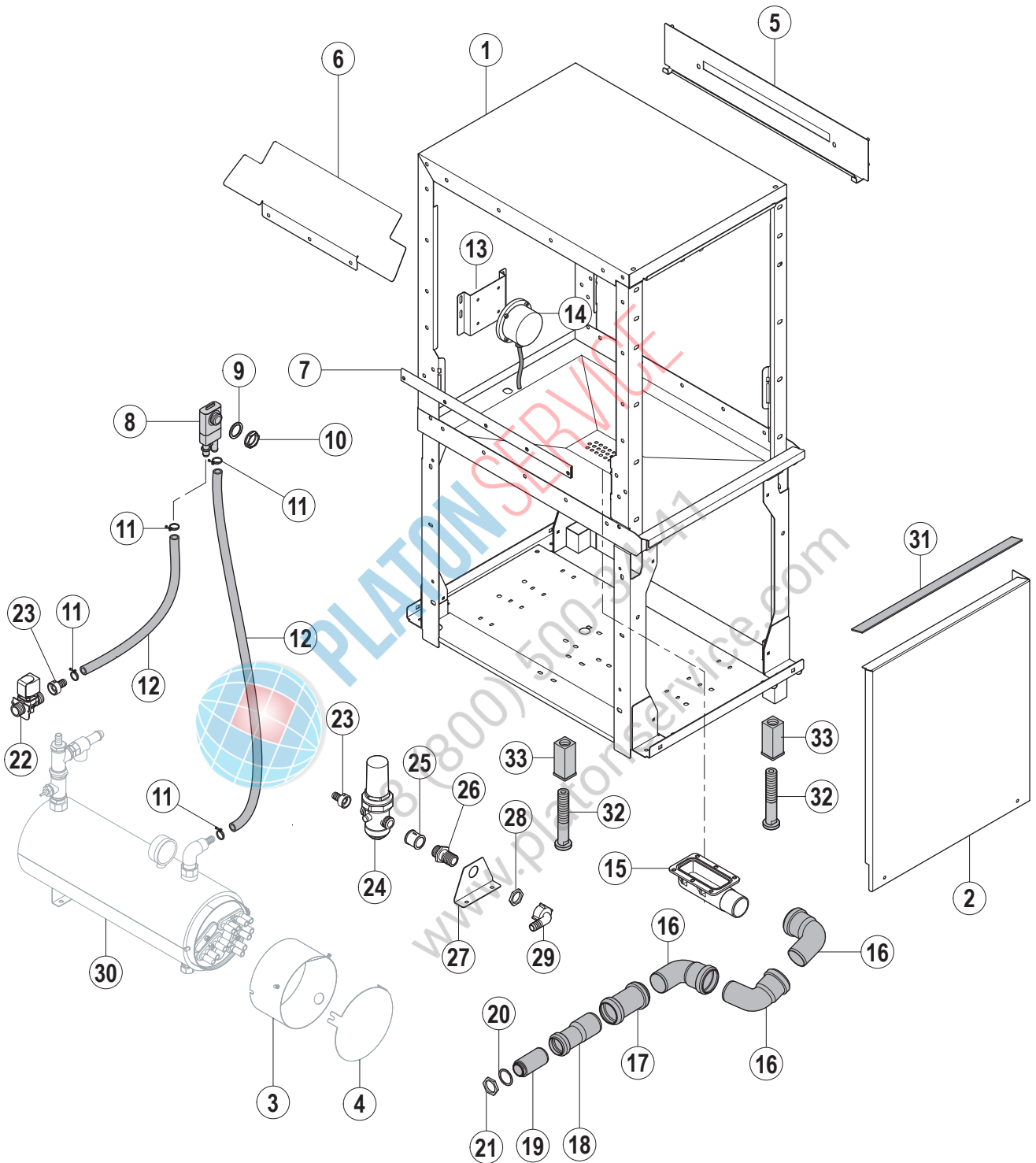

Pos.	A	B			X [mm]	Bemerkung / Remarks / Remarques
		CS	CN	CP		
01	L/R	---	01-296356-001	---		
	R/L	---	01-296356-002	---		
02	L/R	---	01-291407-009	---		
	R/L	---	01-291407-015	---		
		---	01-291407-016	---		
03		---	01-249044-001	---		
04		---	01-296351-001	---		
05		---	01-291434-001	---		
06		---	00-896430-003	---		
07		---	00-325155-003	---		
08		---	00-775759-001	---		
09		---	00-775305-001	---		
10		---	00-324384-000	---		
11		---	00-323945-022	---		
12		---	01-245571-001	---		
13		---	00-868978-002	---		
14		---	00-301745-001	---		
15		---	00-325529-001	---		
16		---	00-230080-001	---		
17		---	00-229680-001	---		
18		---	00-325708-001	---		
19		---	00-774616-001	---		
20		---	00-172986-028	---		
21		---	00-172739-008	---		
22		---	00-297808-010	---		
23		---	00-302201-001	---		
24		---	00-229110-002	---		
25		---	00-603051-000	---		
26		---	01-245850-001	---		
27		---	01-296341-001	---		
28		---	00-172739-002	---		
29		---	00-299240-001	---		
30		---	01-291554-...	---		Details siehe 11.1 / details see 11.1 / détails regardez 11.1
31		---	01-296451-003	---		
32		---	00-325007-001	---		
33		---	00-325008-001	---		





**PLATON** SERVICE

8 (800) 500-34-41

[www.platonservice.com](http://www.platonservice.com)

**CS / CN / CP**

**Trennmodul**

**Disconnecting module**

**Module de passage**

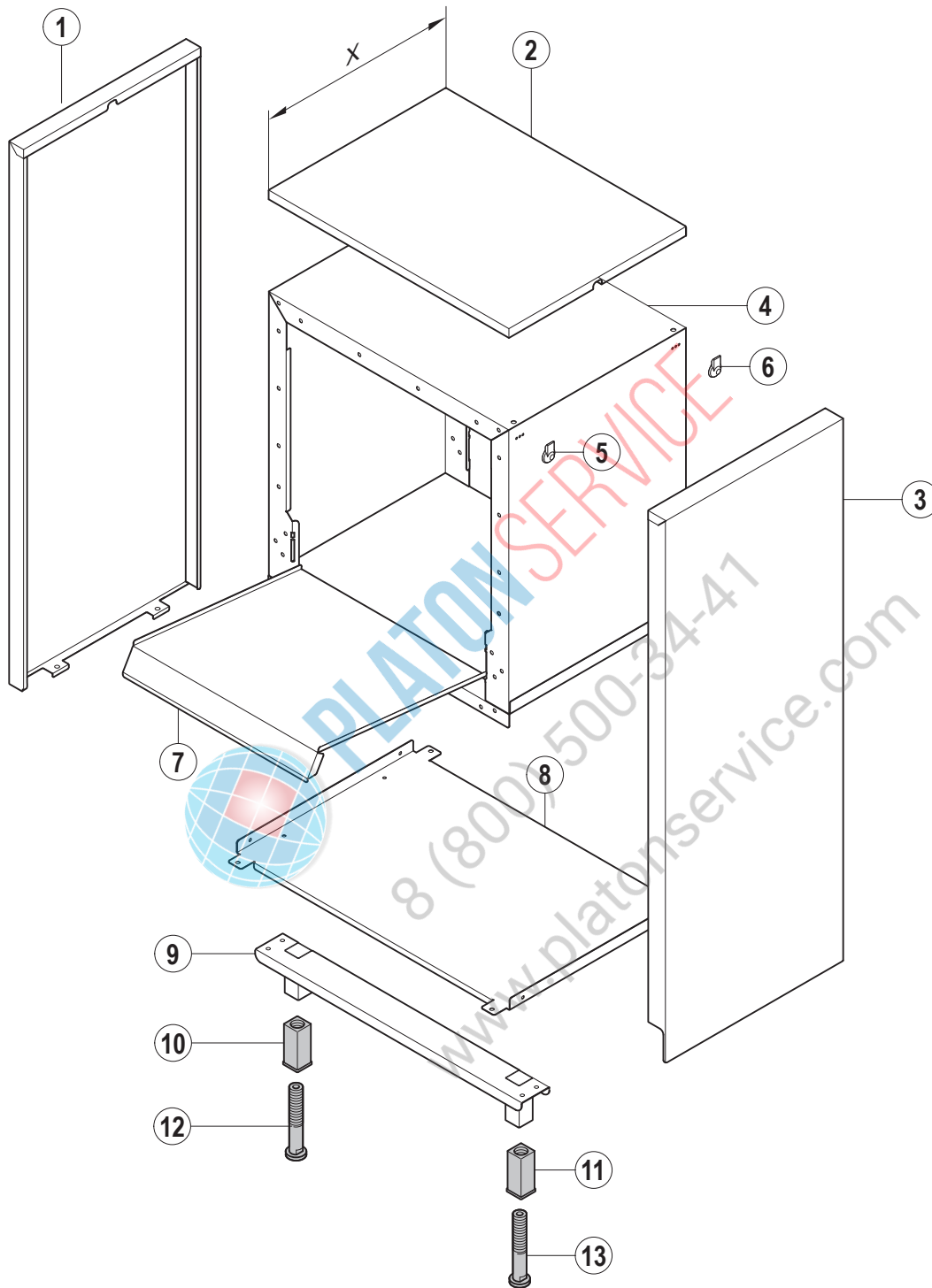

09.1



Pos.	A	B			X [mm]	Bemerkung / Remarks / Remarques
		CS	CN	CP		
01		---	01-291317-004	=	500	
		---	01-291317-008	=	300	
02		---	01-291397-004	=	500	
		---	01-291397-007	=	300	
03		---	01-291866-001	=	500	
		---	01-291866-002	=	300	
04		---	01-291860-001	=	500	
		---	01-291860-002	=	300	
05		---	00-325037-001	=		
06		---	01-291857-001	=	500	
		---	01-291857-002	=	300	
07		---	01-291856-001	=	500	
		---	01-291856-002	=	300	
08		---	01-291366-005	=		
09		---	00-325008-001	=		
10		---	00-325007-001	=		

09.1



PLATON SERVICE  
8 (800) 500-34-47  
www.platonservice.com





**PLATON** SERVICE

8 (800) 500-34-41

[www.platonservice.com](http://www.platonservice.com)

**CS / CN / CP**

**Waschsystem**

**Wash system**

**Système de lavage**

10.1

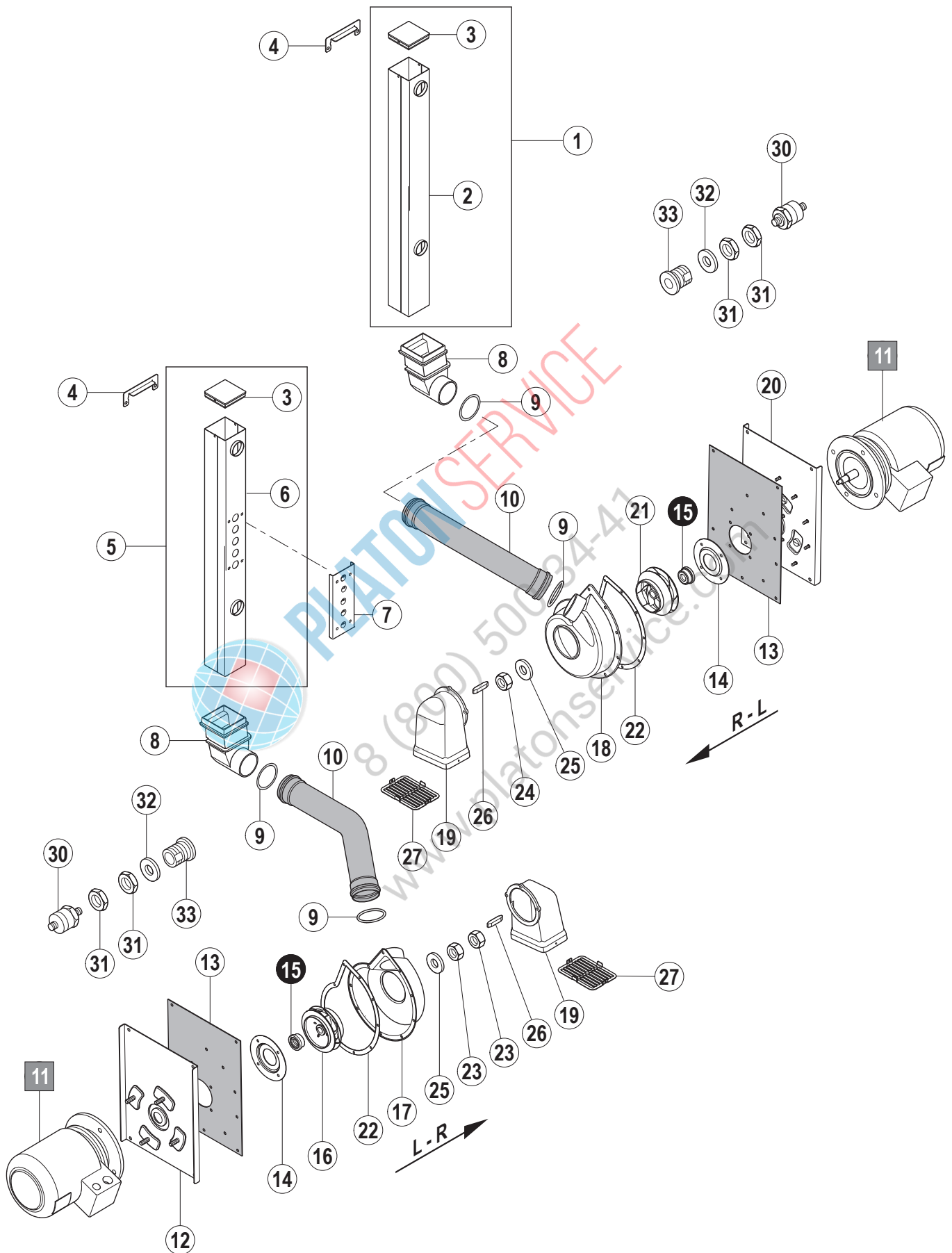

Pos.	A	B			X [mm]	Bemerkung / Remarks / Remarques
		CS	CN	CP		
01		01-245669-005	=	=		
02		01-245110-005	=	=		
03		01-245086-002	=	=		
04		01-245979-001	=	=		
05		---	01-245669-008	=		
06		---	01-245110-008	=		
07		---	01-245428-002	=		
08		01-245055-001	=	=		
09		01-245340-003	=	=		
10		01-245277-001	=	=		
11		01-245176-...	=	=		siehe Schaltplan / see wiring diagram / voir schéma de câblage
12	L/R	01-245835-003	=	=		
13		01-245386-002	=	=		
14		01-245379-001	=	=		
15		01-245033-002	=	=		
16	L/R	01-245162-004	---	---		AR-Modul (50/60 Hz)
	L/R	---	01-245162-003	01-245162-003		S-Modul (50 Hz); AR-Modul (50 Hz)
	L/R	---	01-245162-004	01-245162-004		S-Modul (60 Hz); AR-Modul (60 Hz)
	L/R	---	01-245162-004	01-245162-004		L-Modul (50/60 Hz)
17	L/R	01-245135-004	=	=		
18	R/L	01-245135-005	=	=		
19		01-245713-001	=	=		
20	R/L	01-245835-004	=	=		
21	R/L	01-245088-004	---	---		AR-Modul (50/60 Hz)
	R/L	---	01-245088-003	01-245088-003		S-Modul (50 Hz); AR-Modul (50 Hz)
	R/L	---	01-245088-004	01-245088-004		S-Modul (60 Hz); AR-Modul (60 Hz)
	R/L	---	01-245088-004	01-245088-004		L-Modul (50/60 Hz)
22		01-245459-001	=	=		
23	L/R	00-603465-000	=	=		
24	R/L	00-602504-000	=	=		
25		00-602288-000	=	=		
26		00-609801-000	=	=		
27		01-245377-002	=	=		
30	t	---	---	01-297200-001		
31		---	---	00-172739-001		
32		---	---	00-172986-003		
33		---	---	00-869222-002		

10.2

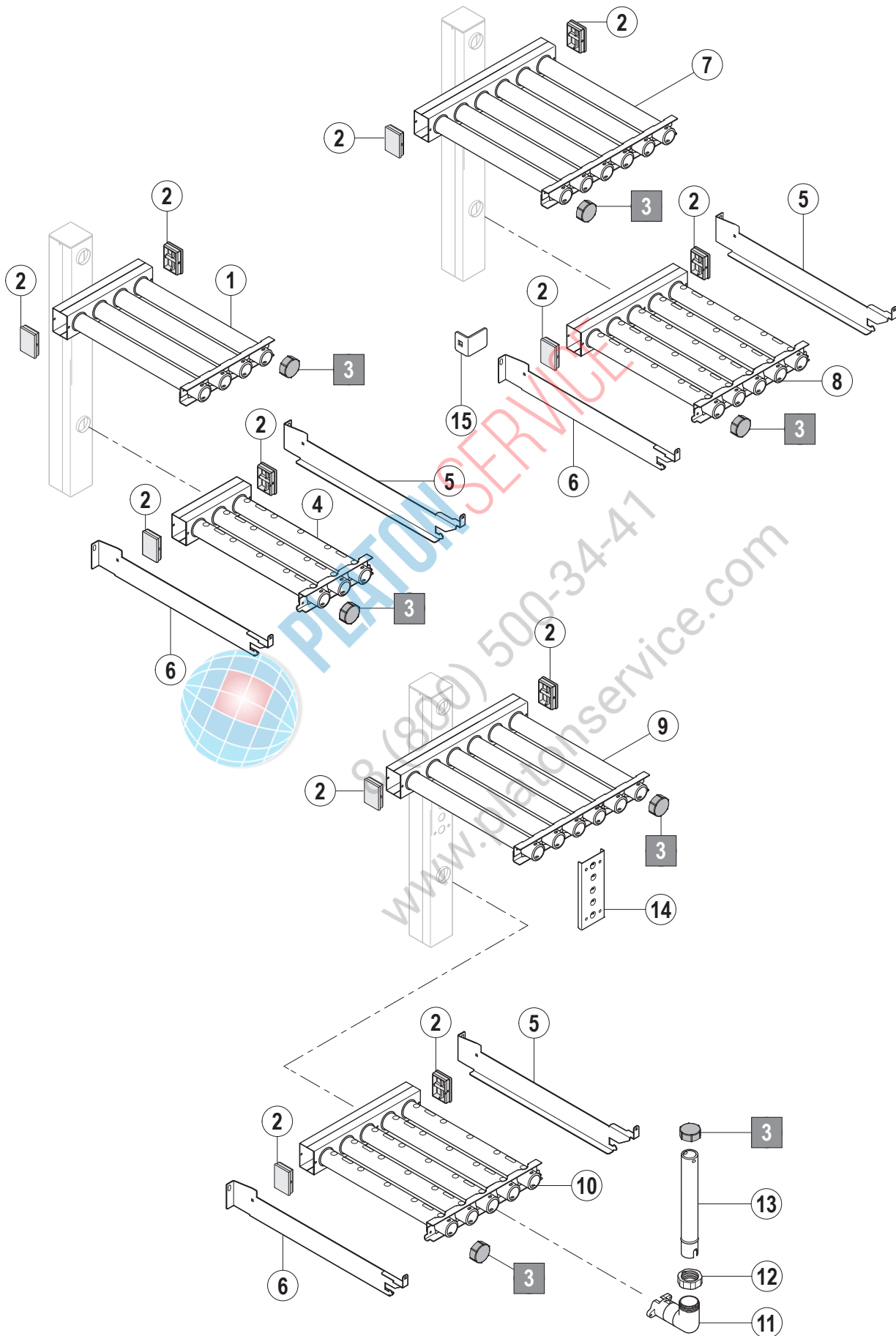

Pos.	A	B			X [mm]	Bemerkung / Remarks / Remarques
		CS	CN	CP		
01	L/R	01-291302-009	---	---		AR-Modul
	R/L	01-291302-011	---	---		AR-Modul
	L/R	---	01-291302-005	=		L-Modul
	R/L	---	01-291302-007	=		L-Modul
	L/R	---	01-291302-017	=		C-Modul
	R/L	---	01-291302-019	=		C-Modul
02		01-245086-001	=	=		
03		01-245084-002	=	=		
04	L/R	01-291302-010	---	---		AR-Modul
	R/L	01-291302-012	---	---		AR-Modul
	L/R	---	01-291302-006	=		L-Modul
	R/L	---	01-291302-008	=		L-Modul
	L/R	---	01-291302-018	=		C-Modul
	R/L	---	01-291302-020	=		C-Modul
05		01-291358-001	=	=		
06		01-291358-002	=	=		
07	L/R	---	01-291302-001	=		AR-Modul, S-Modul
	R/L	---	01-291302-003	=		AR-Modul, S-Modul
08	L/R	---	01-291302-002	=		AR-Modul, S-Modul
	R/L	---	01-291302-004	=		AR-Modul, S-Modul
09	L/R	---	01-291302-015	=		AR-Modul
	R/L	---	01-291302-016	=		AR-Modul
10	L/R	---	01-291302-013	=		AR-Modul
	R/L	---	01-291302-014	=		AR-Modul
11		---	01-296040-001	=		
12		---	01-245424-001	=		
13	L/R	---	01-291869-001	=		
	R/L	---	01-291869-002	=		
14		---	01-245428-002	=		
15		---	01-291886-001	=		



**PLATON**SERVICE

8 (800) 500-34-47

[www.platonservice.com](http://www.platonservice.com)





**PLATON SERVICE**

8 (800) 500-34-41

[www.platonservice.com](http://www.platonservice.com)

**CS / CN / CP**

**Erhitzer**

**Booster**

**Chaudière**

11.1

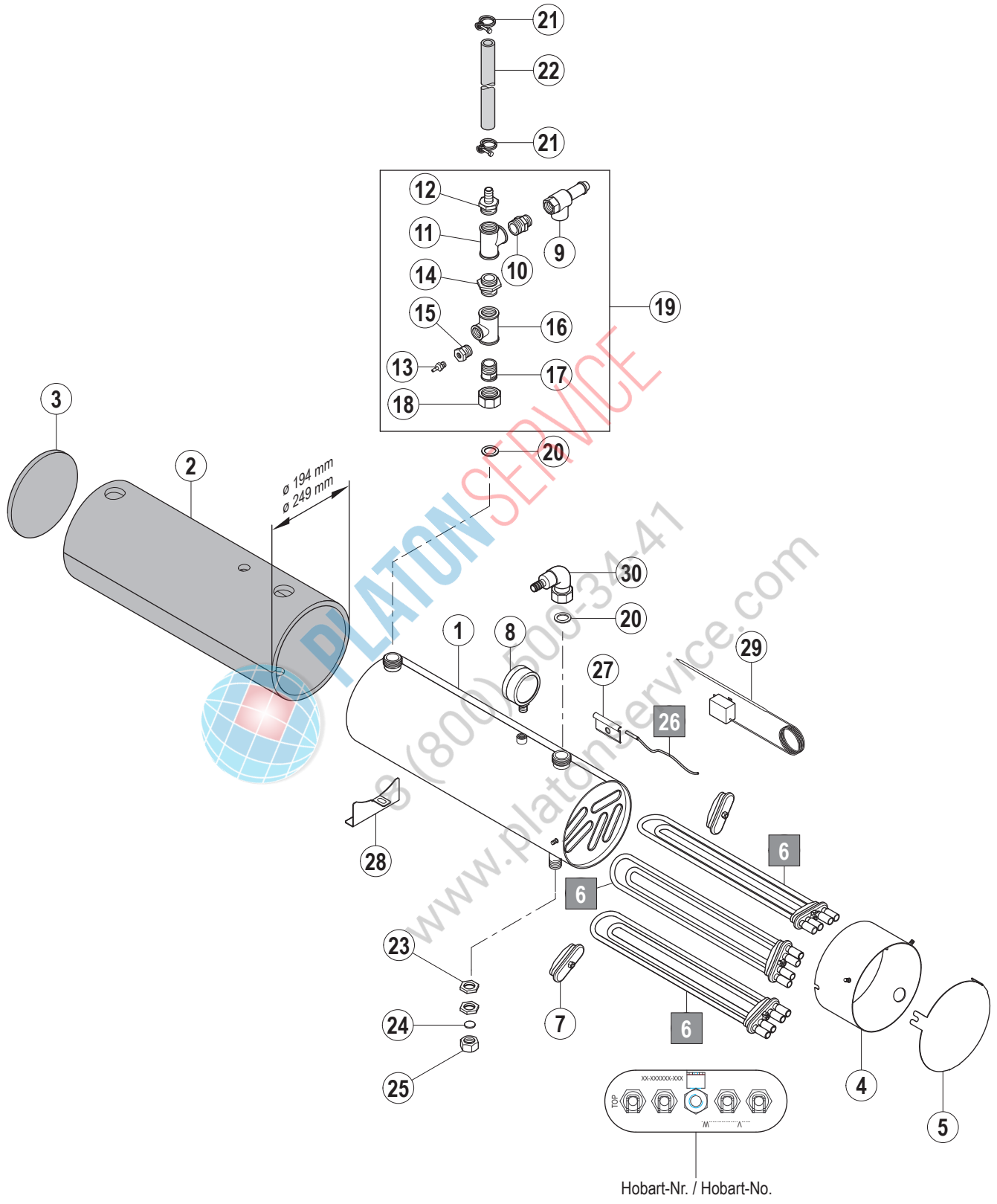

Pos.	A	B			X [mm]	Bemerkung / Remarks / Remarques
		CS	CN	CP		
01		00-897683-001	=	=	Ø194	mit Isolierung / with insulation / avec isolation
		01-241873-001	=	=	Ø249	mit Isolierung / with insulation / avec isolation
02		00-897657-001	=	=	Ø194	
		01-241874-001	=	=	Ø249	
03		00-897657-002	=	=	Ø194	
		01-241876-001	=	=	Ø249	
04		01-249044-001	=	=	Ø194	
		01-249044-002	=	=	Ø249	
05		01-296351-001	=	=	Ø194	
		01-296351-002	=	=	Ø249	
06		00-324637-...	=	=		Nr. siehe Flansch / no. see flange / no. voir bride
07		00-774808-001	=	=		
08		00-229583-001	=	=		
09		00-229621-000	=	=		
10		00-602757-000	=	=		
11		00-603163-000	=	=		
12		00-897680-001	=	=		
13		00-227249-003	=	=		
14		00-227931-000	=	=		
15		01-291287-001	=	=		
16		01-291288-001	=	=		
17		01-291286-001	=	=		
18		00-600806-000	=	=		
19		01-244435-002	=	=		
20		00-168611-003	=	=		
21		00-323945-022	=	=		
22		01-245571-002	=	=		L=2000 mm
23		00-172739-001	=	=		
24		00-168611-022	=	=		
25		00-600588-000	=	=		
26		---	00-775612-001	=		
27		00-775489-001	=	=		
28		01-243201-001	=	=		
29		00-226-505-004	---	---		
30		01-296696-001	=	=		

11.2

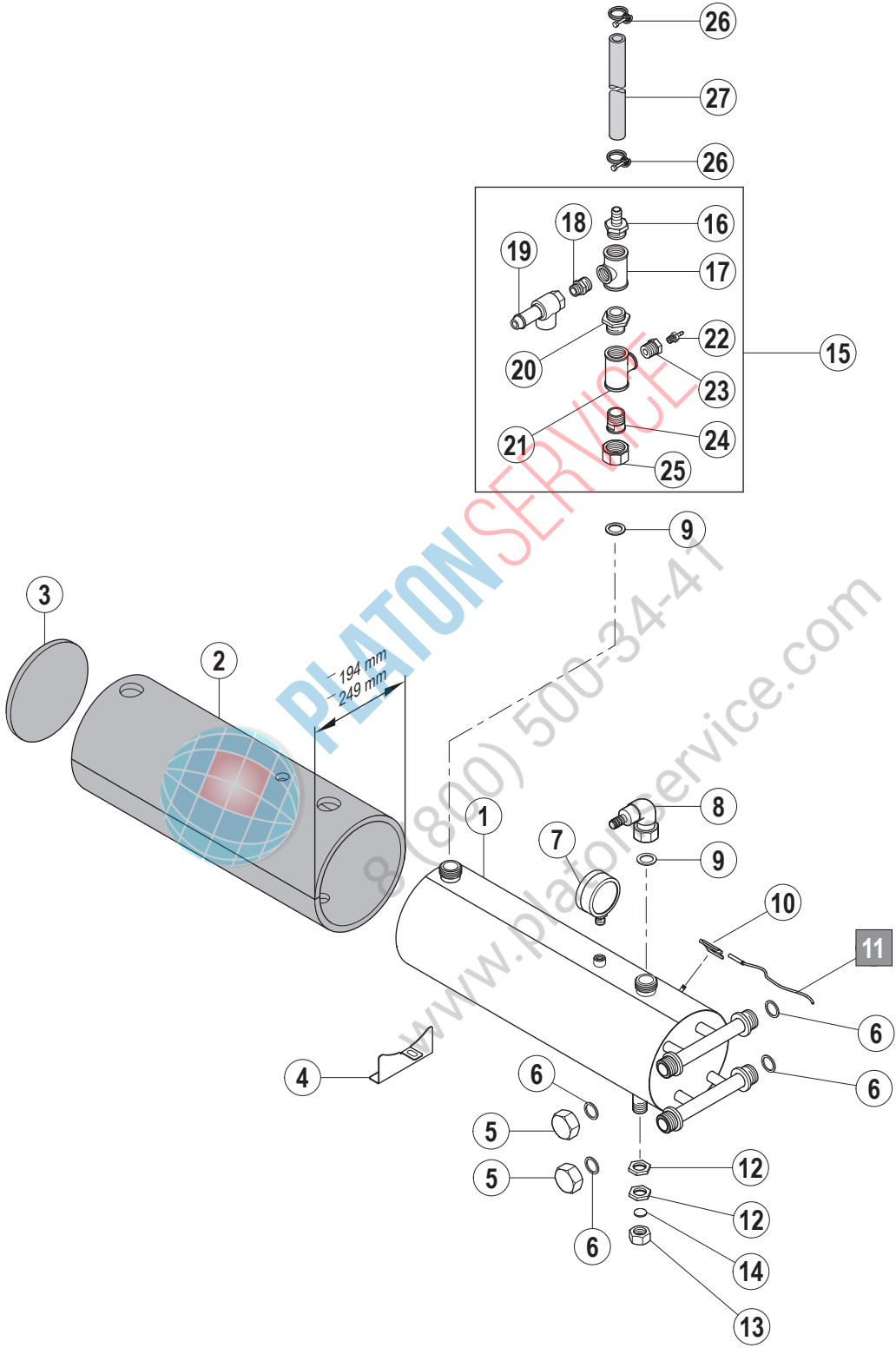

CN 11.2

Pos.	A	B			X [mm]	Bemerkung / Remarks / Remarques
		CS	CN	CP		
01		---	01-245602-002	=	Ø194	mit Isolierung / with insulation / avec isolation
		---	01-245951-002	=	Ø249	mit Isolierung / with insulation / avec isolation
02		---	00-897657-001	=	Ø194	
		---	01-241874-001	=	Ø249	
03		---	00-897657-002	=	Ø194	
		---	01-241876-001	=	Ø249	
04		---	01-243201-001	=		
05		---	01-245605-001	=		
06		---	00-302574-014	=		
07		---	00-229583-001	=		
08		---	01-296696-001	=		
09		---	00-168611-003	=		
10		---	00-775489-001	=		
11		---	00-775612-001	=		
12		---	00-172739-001	=		
13		---	00-600588-000	=		
14		---	00-168611-022	=		
15		---	01-244435-002	=		
16		---	00-897680-001	=		
17		---	00-603163-000	=		
18		---	00-602757-000	=		
19		---	00-229621-000	=		
20		---	00-227931-000	=		
21		---	01-291288-001	=		
22		---	00-227249-003	=		
23		---	01-291287-001	=		
24		---	01-291286-001	=		
25		---	00-600806-000	=		
26		---	00-323945-022	=		
27		---	01-245571-002	=		L=2000 mm





**PLATON** SERVICE

8 (800) 500-34-41

[www.platonservice.com](http://www.platonservice.com)

**CS / CN / CP**

**Spülsystem**

**Rinse system**

**Système de rinçage**

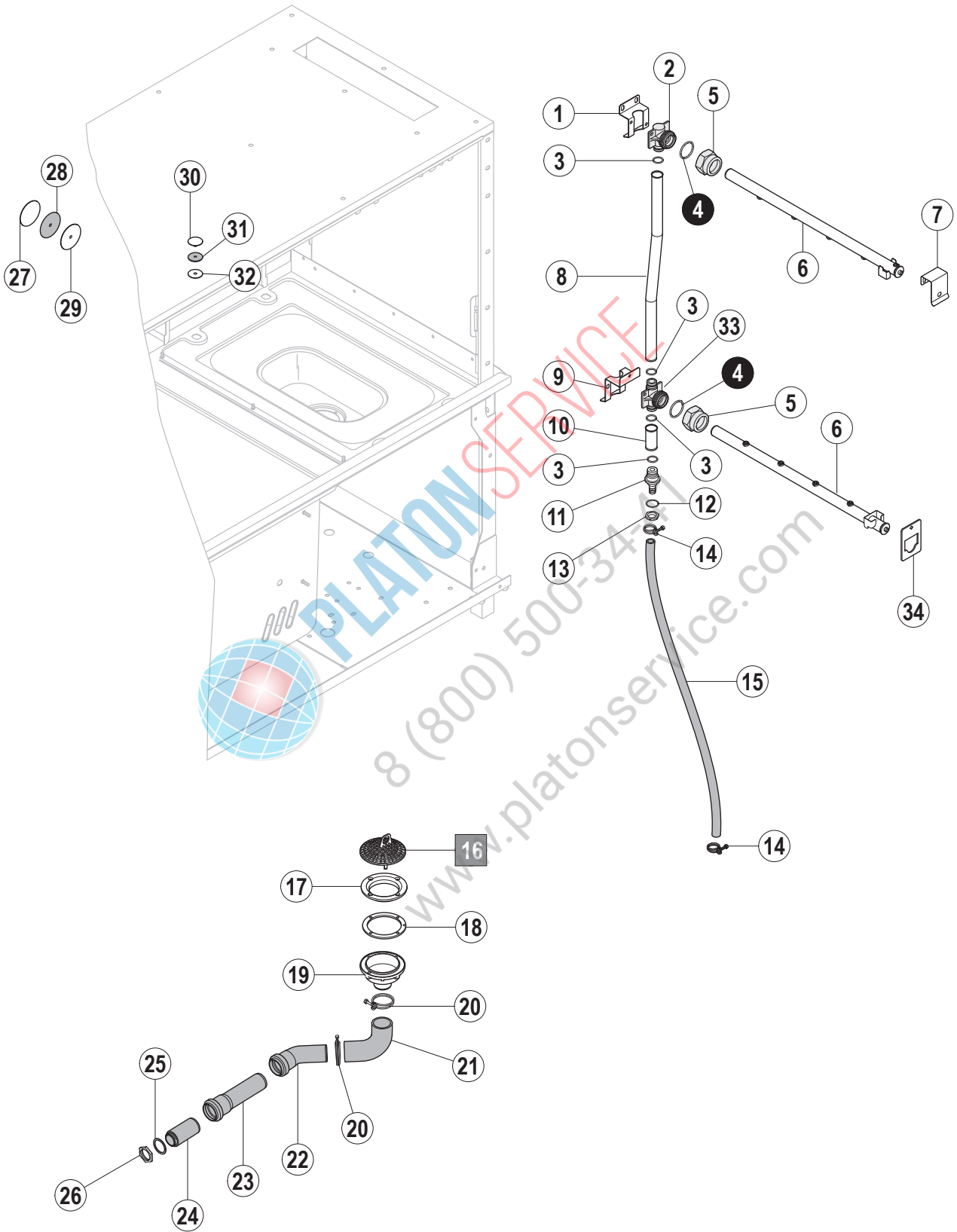

12.1



Pos.	A	B			X [mm]	Bemerkung / Remarks / Remarques
		CS	CN	CP		
01		01-291337-001	=	---		
02		01-245318-002	=	---		
03		01-245340-001	=	---		
04		00-884505-002	=	---		
05		00-885572-001	=	---		
06		01-291340-001	=	---		Mono-Spülung / Mono rinse / Mono rinçage
		01-291340-004	=	---		Demi-Spülung / Demi rinse / Demi rinçage
07		01-245062-001	=	---		
08		01-245323-003	=	---		
09		01-291341-001	=	---		
10		01-291297-001	=	---		
11		01-245329-001	=	---		
12		01-245340-002	=	---		
13		01-172739-009	=	---		
14		00-323945-022	=	---		
15		01-245571-001	=	---		
16		00-775750-001	=	---		
17		00-324053-000	=	---		
18		00-324056-000	=	---		
19		01-291536-001	=	---		
20		00-323945-053	=	---		
21		01-291527-002	=	---		
22		00-377340-003	=	---		
23		00-325706-013	=	---		
24		00-774616-001	=	---		
25		00-172986-028	=	---		
26		00-172739-008	=	---		
27		00-869137-001	=	---		
28		00-168611-023	=	---		
29		00-696943-014	=	---		
30		00-869137-003	=	---		
31		00-168611-024	=	---		
32		00-696943-030	=	---		
33		01-245318-001	=	---		
34		01-291351-001	=	---		Mono-Spülung / Mono rinse / Mono rinçage
		01-291351-004	=	---		Demi-Spülung / Demi rinse / Demi rinçage

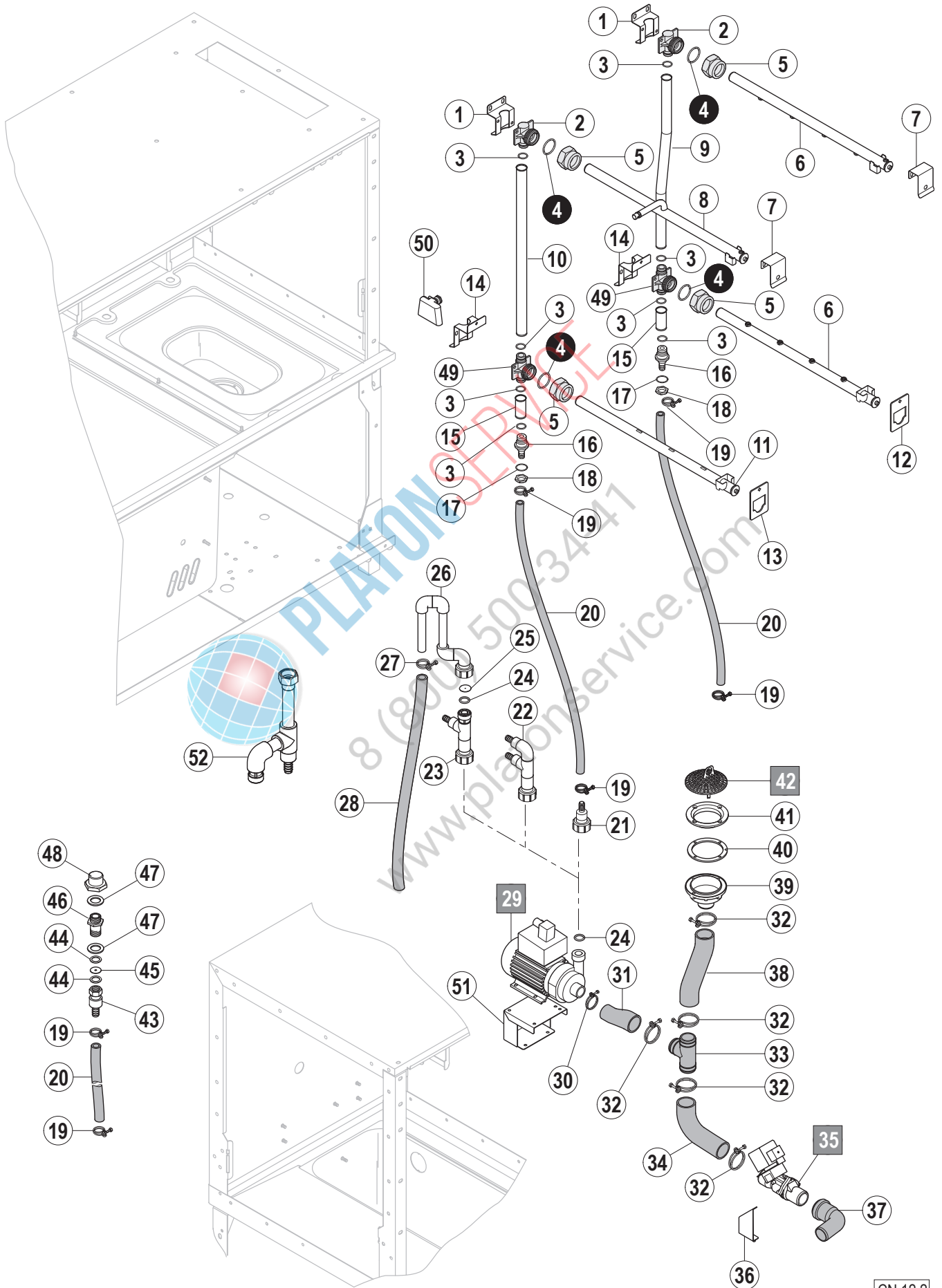

12.2

Pos.	A	B			X [mm]	Bemerkung / Remarks / Remarques
		CS	CN	CP		
01		01-291337-001	=	---		
02		01-245318-002	=	---		
03		01-245340-001	=	---		
04		00-884505-002	=	---		
05		00-885572-001	=	---		
06		01-291340-001	=	---		"Ab Serien- Nr.: 86 67 00001 siehe Kapitel 12.3 starting from serial no. 86 67 00001 see chapter 12.3 à partir du numéro de série 86 67 00001 voir le chapitre 12.3"
07		01-245062-001	=	---		
08		01-291305-001	=	---		<b>Duo-Spülung / dual rinse / double rinçage</b>
	L/R	---	01-291305-002	---		<b>3-fach Spülung / triple rinse / triple rinçage</b>
	R/L	---	01-291305-003	---		<b>3-fach Spülung / triple rinse / triple rinçage</b>
09		01-245323-003	=	---		"Ab Serien- Nr.: 86 67 00001 siehe Kapitel 12.3 starting from serial no. 86 67 00001 see chapter 12.3 à partir du numéro de série 86 67 00001 voir le chapitre 12.3"
10		01-291297-002	=	---		
11		01-291305-001	=	---		
12		01-291351-001	=	---		
13	L/R	01-291351-002	=	---		
	R/L	01-291351-003	=	---		
14		01-291341-001	=	---		
15		01-291297-001	=	---		
16		01-245329-001	=	---		
17		01-245340-002	=	---		
18		00-172739-009	=	---		
19		00-323945-022	=	---		
20		01-245571-001	=	---		L=1000 mm
21		00-895735-001	=	---		
22		---	01-291679-001	---		
23		---	01-291679-002	---		
24		---	00-067500-072	---		
25		---	00-699119-041	---		
26		---	01-245742-001	---		
27		---	00-323945-033	---		
28		---	00-226994-009	---		L=900 mm
29		---	00-323592-...	---		siehe Schaltplan / see wiring diagram / voir schéma de câblage
30		00-323945-040	=	---		
31		01-291526-001	=	---		
32		00-323945-053	=	---		
33		01-291562-001	=	---		
34		01-291527-001	=	---		
35		00-774683-...	=	---		siehe Schaltplan / see wiring diagram / voir schéma de câblage
36		01-291686-001	=	---		
37		00-230080-002	=	---		
38		01-291525-001	=	---		
39		01-291536-001	=	---		
40		00-324056-000	=	---		
41		00-324053-000	=	---		
42		00-775750-001	=	---		
43		---	01-245992-002	---		
44		---	00-172986-034	---		

Pos.	A	B			X [mm]	Bemerkung / Remarks / Remarques
		CS	CN	CP		
45		---	01-245857-005	---		
46		---	00-227931-000	---		
47		---	00-172986-027	---		
48		---	00-774670-001	---		
49		---	01-245318-001	---		
50		00-324858-001	=	---		
51		01-296093-001	=	---		
52		---	01-247089-001	---		



PLATON SERVICE

8 (800) 500-34-47

www.platonservice.com



**PLATON** SERVICE

8 (800) 500-34-47

[www.platonservice.com](http://www.platonservice.com)

12.3

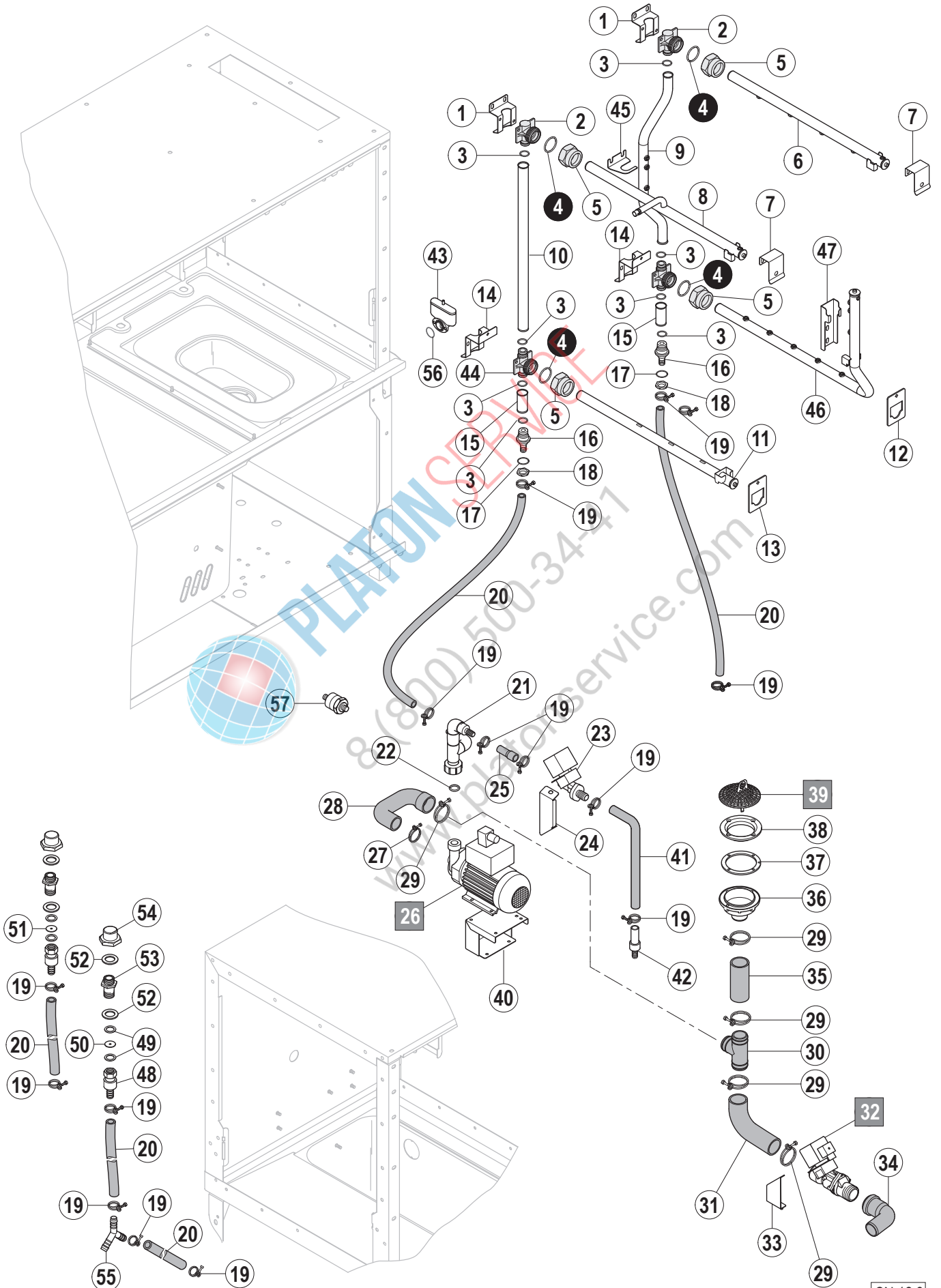

CN 12.3

Pos.	A	B			X [mm]	Bemerkung / Remarks / Remarques
		CS	CN	CP		
01		---	---	01-291337-001		
02		---	---	01-245318-002		
03		---	---	01-245340-001		
04		---	---	00-884505-002		
05		---	---	00-885572-001		
06		---	---	01-291340-002		
07		---	---	01-245062-001		
08	L/R	---	---	01-291305-002		
	R/L	---	---	01-291305-003		
09	L/R	---	---	01-291353-001		
	R/L	---	---	01-291355-001		
10		---	---	01-291297-002		
11		---	---	01-291305-001		
12		---	---	01-291351-001		
13	L/R	---	---	01-291351-002		
	R/L	---	---	01-291351-003		
14		---	---	01-291341-001		
15		---	---	01-291297-001		
16		---	---	01-245329-001		
17		---	---	01-245340-002		
18		---	---	00-172739-009		
19		---	---	00-323945-022		
20		---	---	01-245571-001	L=1000 mm	
21	L/R	---	---	01-291679-003	ohne / without / sans Pos. 57	
	R/L	---	---	01-291679-004	ohne / without / sans Pos. 57	
	L/R	---	---	01-291679-007	mit / with / avec Pos. 57	
	R/L	---	---	01-291679-008	mit / with / avec Pos. 57	
22		---	---	00-067500-072		
23		---	---	00-323592-...	siehe Schaltplan / see wiring diagram / voir schéma de câblage	
24	L/R	---	---	01-291689-001		
	R/L	---	---	01-291687-001		
25		---	---	00-887667-002		
26		---	---	00-781237-...	siehe Schaltplan / see wiring diagram / voir schéma de câblage	
27		---	---	00-323945-040		
28		---	---	01-291691-001		
29		---	---	00-323945-053		
30		---	---	01-291562-001		
31		---	---	01-291527-001		
32		---	---	00-774683-...	siehe Schaltplan / see wiring diagram / voir schéma de câblage	
33		---	---	01-291686-001		
34		---	---	00-230080-002		
35		---	---	01-291525-002		
36		---	---	01-291536-001		
37		---	---	00-324056-000		
38		---	---	00-324053-000		
39		---	---	00-775750-001		
40		---	---	01-296093-001		
41		---	---	00-324077-026		
42		---	---	00-897679-003		
43		---	---	01-240076-002		

Pos.	A	B			X [mm]	Bemerkung / Remarks / Remarques
		CS	CN	CP		
44		---	---	01-245318-001		
45		---	---	01-291346-001		
46	L/R	---	---	01-291345-001		
	R/L	---	---	01-291350-001		
47		---	---	01-291347-001		
48		---	---	01-245992-002		
49		---	---	00-172986-034		
50		---	---	01-245857-003		Blende AR-Waschung / diaphragm AR wash / diaphragme AR lavage
51		---	---	01-245857-004		Blende Vorwaschung / diaphragm prewash / diaphragme pré-lavage
52		---	---	00-172986-027		
53		---	---	00-227931-000		
54		---	---	00-774670-001		
55		---	---	00-174047-001		
56		---	---	00-276903-056		
57	---	---	---	01-297200-001		

12.3



PLATON SERVICE  
 8 (800) 500-34-47  
 www.platonservice.com





**PLATON**SERVICE

8 (800) 500-34-41

[www.platonservice.com](http://www.platonservice.com)

**CS / CN / CP**

**Füllsystem**

**Filling system**

**Système de remplissage**

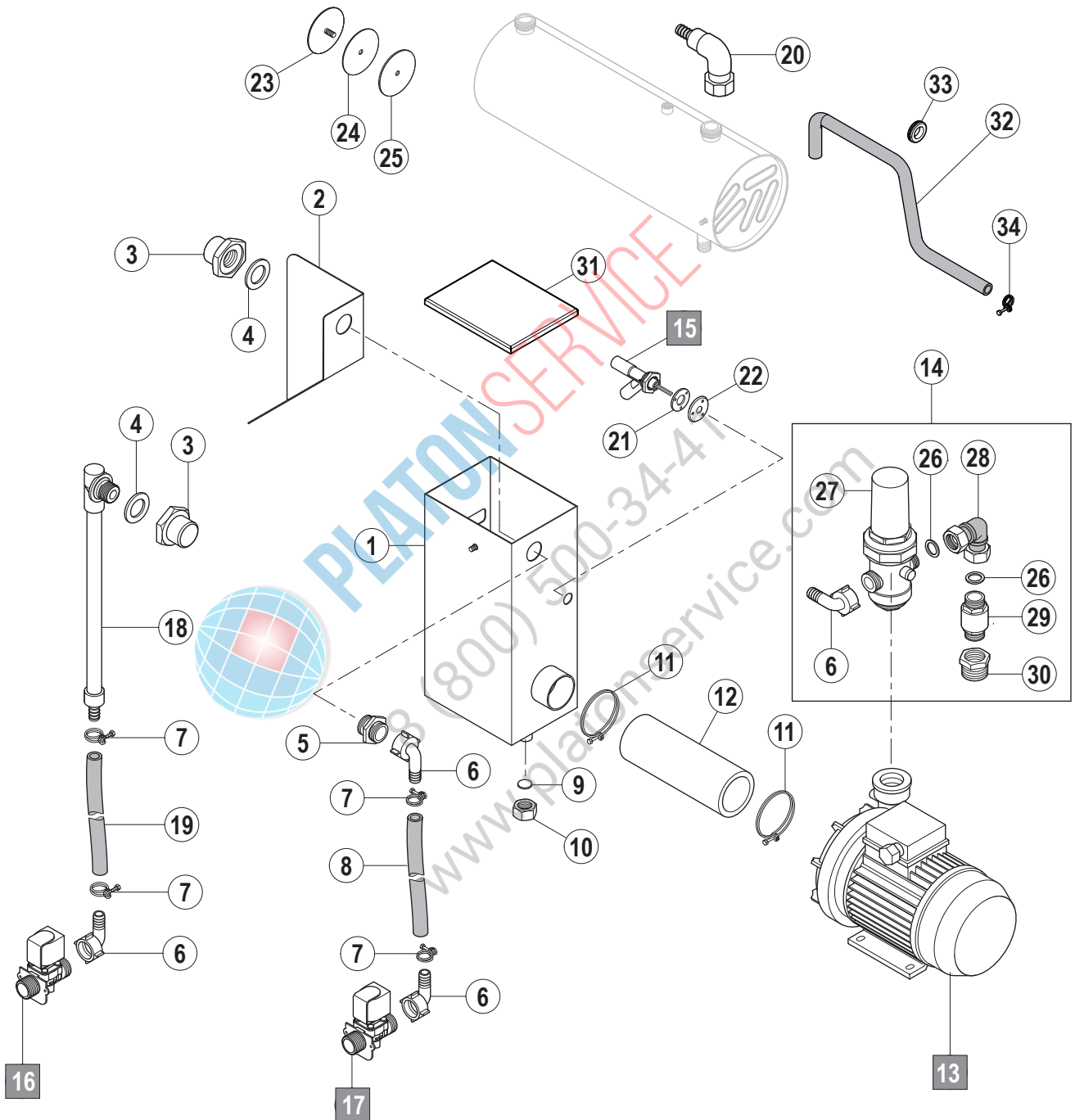

13.1

Pos.	A	B			X [mm]	Bemerkung / Remarks / Remarques
		CS	CN	CP		
01		01-291436-002	=	---		
02		01-291662-001	=	---		
03		00-774670-001	=	---		
04		00-172986-027	=	---		
05		00-227931-000	=	---		
06		00-299240-001	=	---		
07		00-323945-022	=	---		
08		01-245571-013	=	---		L=1200 mm
09		00-168611-022	=	---		
10		00-600588-000	=	---		
11		00-323945-064	=	---		
12		00-883142-006	=	---		
13		00-897662-...	=	---		siehe Schaltplan / see wiring diagram / voir schéma de câblage
14		01-291709-001	=	---		
15		00-735171-...	=	---		siehe Schaltplan / see wiring diagram / voir schéma de câblage
16		00-297808-012	=	---		<b>Warmwasser / hot water / eau chaude</b>
17		00-297808-010	=	---		<b>Kaltwasser / cold water / eau froide</b>
18		00-897686-001	=	---		
19		01-245571-002	=	---		L=2000 mm
20		01-296696-001	=	---		
21		00-774034-001	=	---		
22		00-774010-001	=	---		
23		00-869137-001	=	---		
24		00-168611-023	=	---		
25		00-696943-014	=	---		
26		00-168611-009	=	---		
27		00-229110-002	=	---		
28		01-291708-001	=	---		
29		00-897668-001	=	---		
30		00-603076-000	=	---		
31		01-291152-005	=	---		
32		01-518215-001	=	---		
33		00-227748-014	=	---		
34		00-323945-020	=	---		

13.2

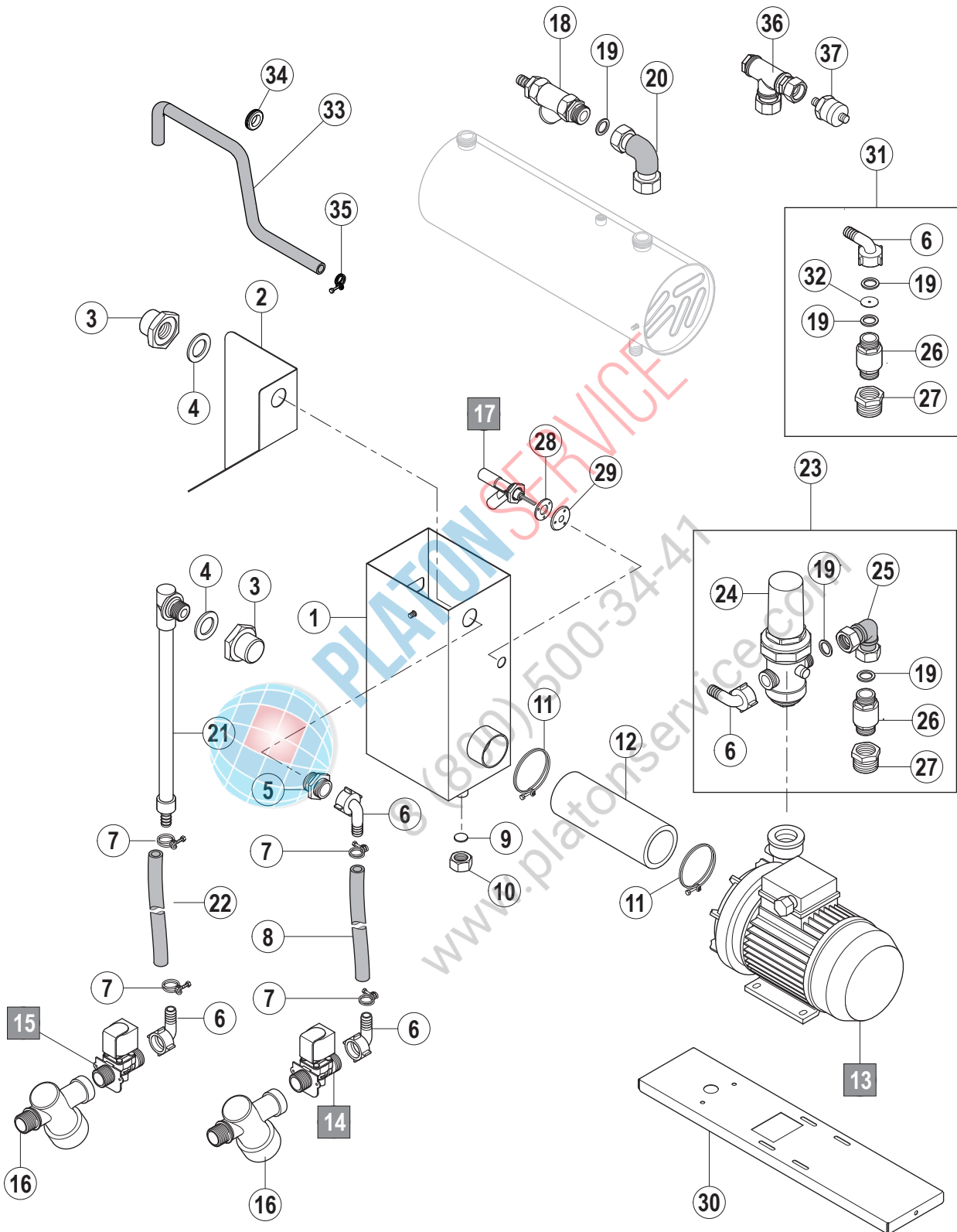

Pos.	A	B			X [mm]	Bemerkung / Remarks / Remarques
		CS	CN	CP		
01		---	---	01-291436-001		
02		---	---	01-291662-001		
03		---	---	00-774670-001		
04		---	---	00-172986-027		
05		---	---	00-227931-000		
06		---	---	00-299240-001		
07		---	---	00-323945-022		
08		---	---	01-245571-013		L=1200 mm
09		---	---	00-168611-022		
10		---	---	00-600588-000		
11		---	---	00-323945-068		
12		---	---	00-883142-006		
13		---	---	00-897662-...		siehe Schaltplan / see wiring diagram / voir schéma de câblage
14		---	---	00-297808-012		<b>Warmwasser / hot water / eau chaude</b>
15		---	---	00-297808-010		<b>Kaltwasser / cold water / eau froide</b>
16		---	---	00-774810-001		
17		---	---	00-735171-...		siehe Schaltplan / see wiring diagram / voir schéma de câblage
18		---	---	01-243891-002		
19		---	---	00-168611-009		
20		---	---	01-296696-002		
21		---	---	00-897686-001		
22		---	---	01-245571-002		L=2000 mm
23		---	---	01-291709-001		ohne <b>SENSOTRONIC</b> / without <b>SENSOTRONIC</b> / sans <b>SENSOTRONIC</b>
24		---	---	00-229110-002		
25		---	---	01-291708-001		
26		---	---	00-897668-001		
27		---	---	00-603076-000		
28		---	---	00-774034-001		
29		---	---	00-774010-001		
30		---	---	01-296094-001		
31		---	---	01-291709-003		mit <b>SENSOTRONIC</b> / with <b>SENSOTRONIC</b> / avec <b>SENSOTRONIC</b>
32		---	---	01-245857-006		
33		---	---	01-518215-001		
34		---	---	00-227748-014		
35		---	---	00-323945-020		
36		---	---	01-296696-005		
37		---	---	01-297200-001		

13.3

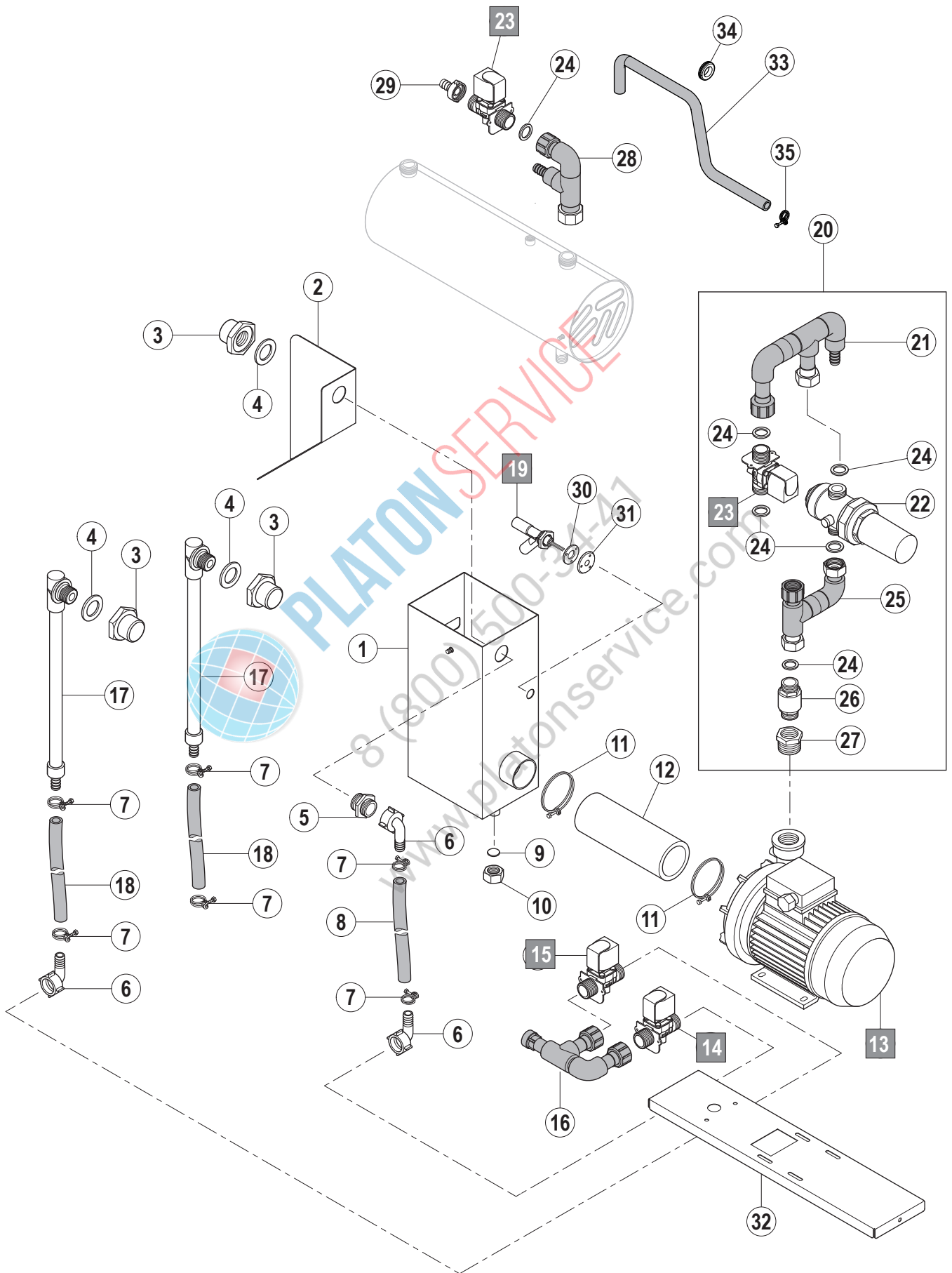

CN 13.3b

Pos.	A	B			X [mm]	Bemerkung / Remarks / Remarques
		CS	CN	CP		
01		---	01-291436-001	---		
02		---	01-291662-001	---		
03		---	00-774670-001	---		
04		---	00-172986-027	---		
05		---	00-227931-000	---		
06		---	00-299240-001	---		
07		---	00-323945-022	---		
08		---	01-245571-013	---		L=1200 mm
09		---	00-168611-022	---		
10		---	00-600588-000	---		
11		---	00-323945-064	---		
12		---	00-883142-006	---		
13		---	00-897662-...	---		siehe Schaltplan / see wiring diagram / voir schéma de câblage
14		---	00-297808-007	---		<b>Kaltwasser / cold water / eau froide</b>
15		---	00-297808-012	---		<b>Warmwasser / hot water / eau chaude</b>
16		---	00-775112-...	---		siehe Schaltplan / see wiring diagram / voir schéma de câblage
17		---	00-897686-001	---		
18		---	01-245571-002	---		L=2000 mm
19		---	00-735171-002	---		
20		---	01-291709-002	---		
21		---	01-245694-002	---		
22		---	00-229110-002	---		
23		---	00-297808-008	---		
24		---	00-168611-009	---		
25		---	01-245693-001	---		
26		---	00-897668-001	---		
27		---	00-603076-000	---		
28		---	01-296696-004	---		
29		---	00-302201-001	---		
30		---	00-774034-001	---		
31		---	00-774010-001	---		
32		---	01-296094-001	---		
33		---	01-518215-001	---		
34		---	00-227748-014	---		
35		---	00-323945-020	---		

13.4

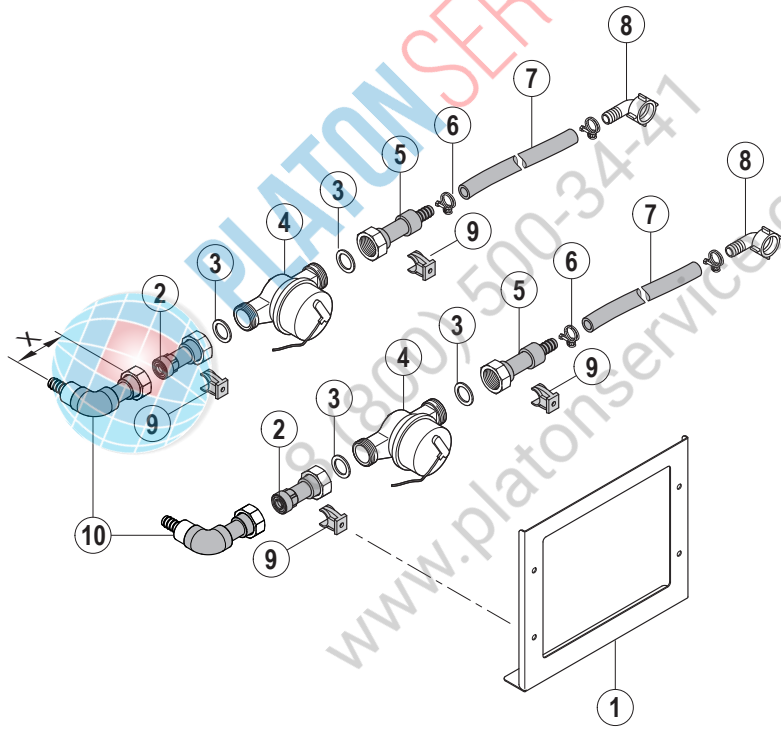



Pos.	A	B			X [mm]	Bemerkung / Remarks / Remarques
		CS	CN	CP		
01		01-291298-001	=	=		
02		01-291004-002	=	=		
03		00-168611-003	=	=		
04		01-244744-002	=	=		
05		01-291004-006	=	=		
06		00-323945-022	=	=		
07		01-245571-014	=	=		L=500 mm
08		00-299240-001	=	=		
09		00-228810-002	=	=		
10		01-291004-008	=	=	72	
		01-291004-009	=	=	87	



PLATON SERVICE  
8 (800) 500-34-41  
www.platonservice.com

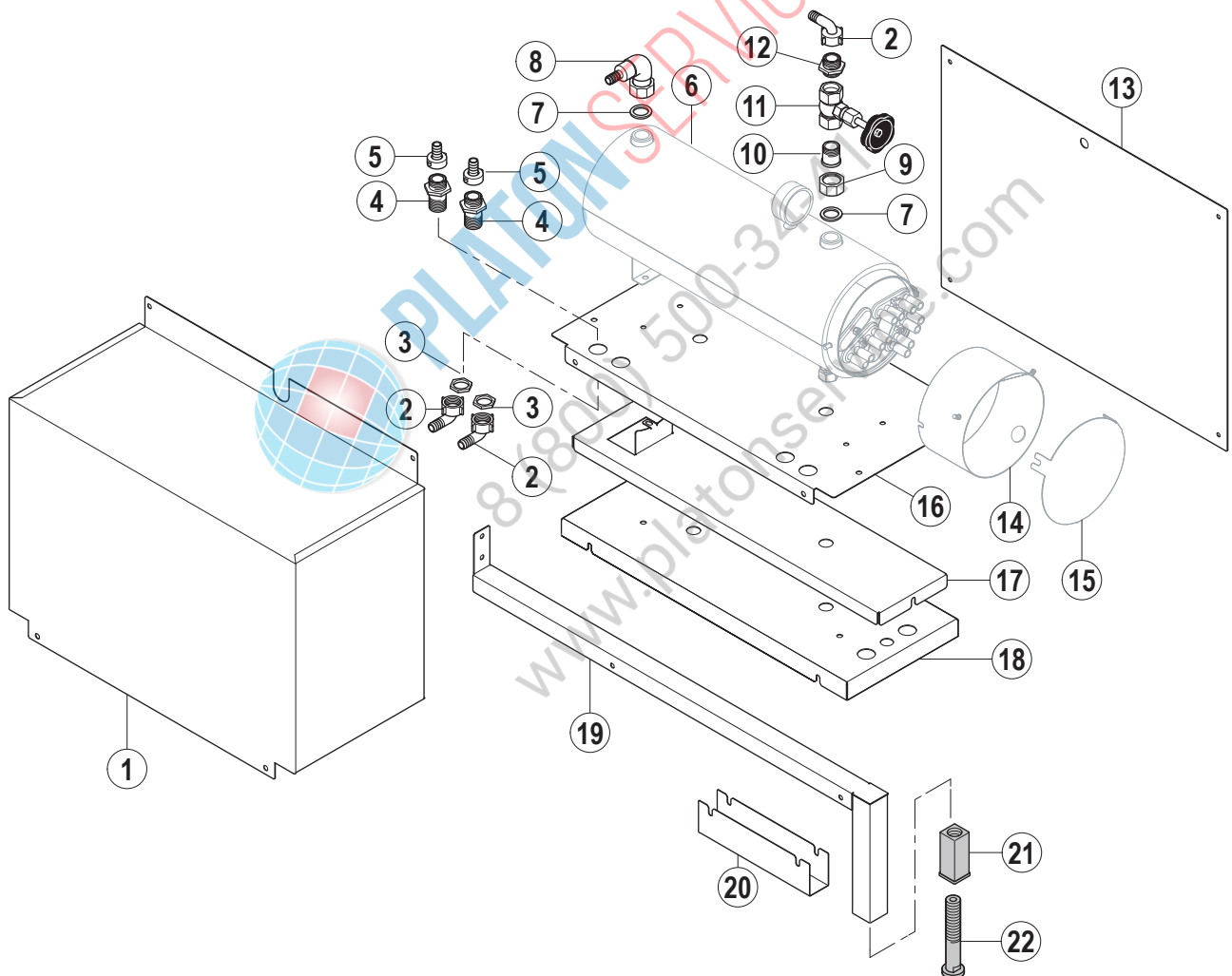

13.5

Pos.	A	B			X [mm]	Bemerkung / Remarks / Remarques
		CS	CN	CP		
01		---	01-242110-001	=		Nur bei <b>CDS</b> / (CDC bis Serien-Nr.: 8646 7490)
		---	01-242110-004	=		Nur bei <b>CDC-C</b> -Trocknung
		---	01-518280-001	=		Nur bei <b>CDC</b> ab Serien-Nr.: 8646 7491
02		---	00-299240-001	=		
03		---	00-172739-002	=		
04		---	01-245850-001	=		
05		---	00-302201-001	=		
06		---	01-291554-...	=		Boiler siehe Schaltplan / Booster see wiring diagram / Chaudière voir schéma de câblage
07		---	00-168611-003	=		
08		---	01-296696-001	=		
09		---	00-600806-000	=		
10		---	00-602403-000	=		
11		---	01-241853-002	=		
12		---	00-227931-000	=		
13		---	01-242129-001	=		Nur bei <b>CDS</b>
		---	01-242129-002	=		Nur bei <b>CDC-C</b> -Trocknung
		---	01-242129-003	=		Nur bei <b>CDC</b> ab Serien-Nr.: 8646 7491
14		---	01-249044-001	=		
15		---	01-296351-001	=		
16		---	01-296271-001	=		nur bei <b>CDS</b> -Trocknung / only <b>CDS</b> -Dryer / seulement <b>CDS</b> -Séchage
		---	01-296271-002	=		nur bei <b>CDC-C</b> -Trocknung / only <b>CDC-C</b> -Dryer / seulement <b>CDC-C</b> -Séchage
17		---	01-245923-004	=		nur bei <b>DS</b> -Trocknung / only <b>DS</b> -Dryer / seulement <b>DS</b> -Séchage
18		---	01-242120-004	=		nur bei <b>CDC</b> -Trocknung / only <b>CDC</b> -Dryer / seulement <b>CDC</b> -Séchage
19		---	01-296221-001	=		nur bei <b>CDC</b> -Trocknung / only <b>CDC</b> -Dryer / seulement <b>CDC</b> -Séchage
20		---	01-243861-001	=		nur bei <b>CDC</b> -Trocknung / only <b>CDC</b> -Dryer / seulement <b>CDC</b> -Séchage
21		---	00-325008-001	=		
22		---	00-325007-001	=		



**PLATON**SERVICE

8 (800) 500-34-47

[www.platonservice.com](http://www.platonservice.com)



**PLATON**SERVICE

8 (800) 500-34-41

[www.platonservice.com](http://www.platonservice.com)

**CS / CN / CP**

**Wärmerückgewinnung**

**Heat recovery**

**Récupération de la chaleur**

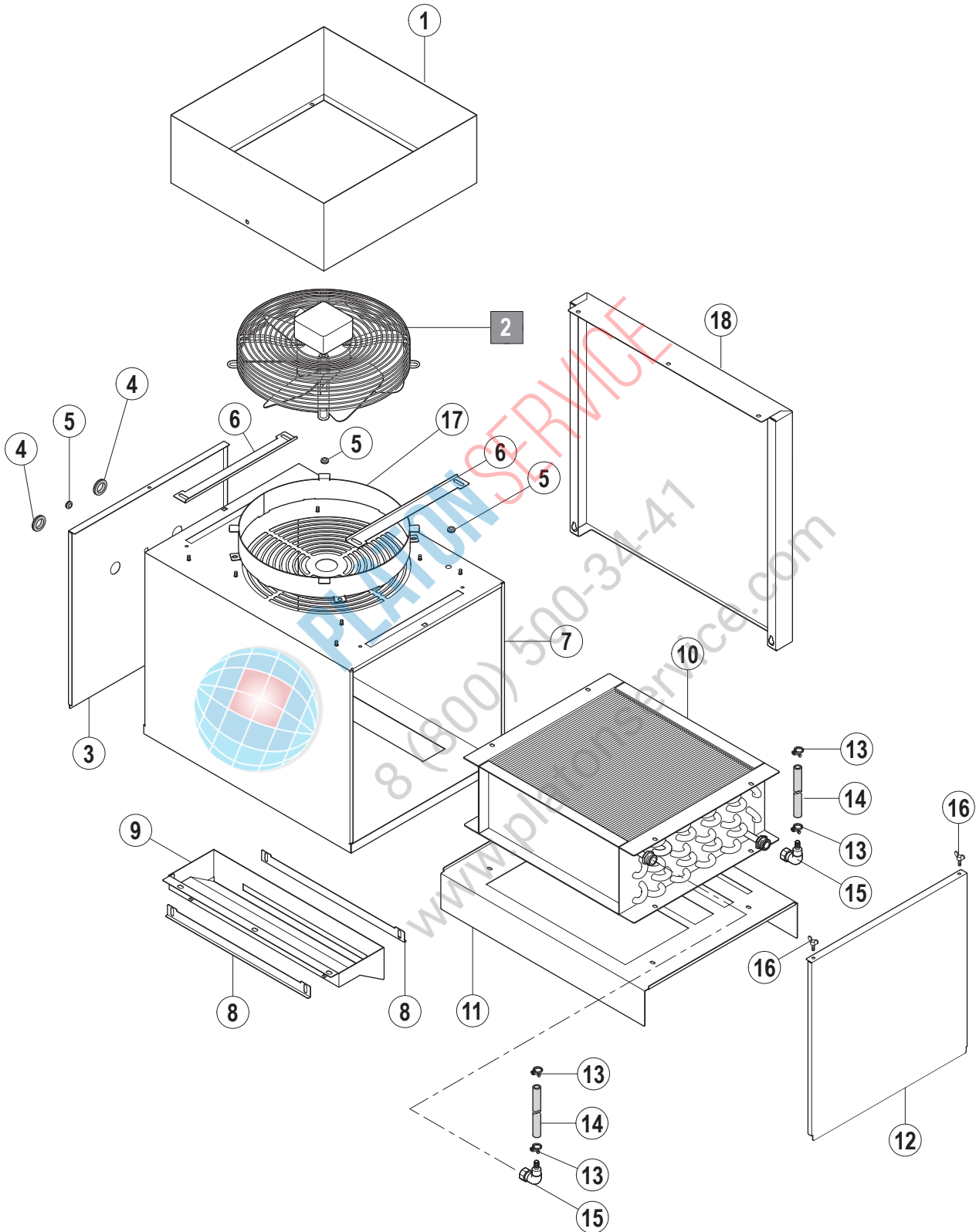

14.1

CN 14.1

Pos.	A	B			X [mm]	Bemerkung / Remarks / Remarques
		CS	CN	CP		
01		---	01-245744-002	=		
02		---	00-781492-...	=		siehe Schaltplan / see wiring diagram / voir schéma de câblage
03		---	01-245206-003	=		
04		---	00-227748-004	=		
05		---	00-227748-001	=		
06		---	01-291395-002	=		
07		---	01-291392-001	=		
08		---	01-291395-001	=		
09	L/R	---	01-291394-001	=		
	R/L	---	01-291394-002	=		
10		---	01-245490-007	=		standard
		---	01-245490-008	=		CrNi / SST / inox
11		---	01-245274-004	=		
12		---	01-245206-001	=		
13		---	00-323945-022	=		
14		---	01-245571-002	=		L=2000 mm
15		---	00-299240-001	=		
16		---	00-609851-000	=		
17		---	00-781377-002	=		
18		---	01-296449-001	=		



PLATON SERVICE  
8 (800) 500-34-47  
www.platonservice.com

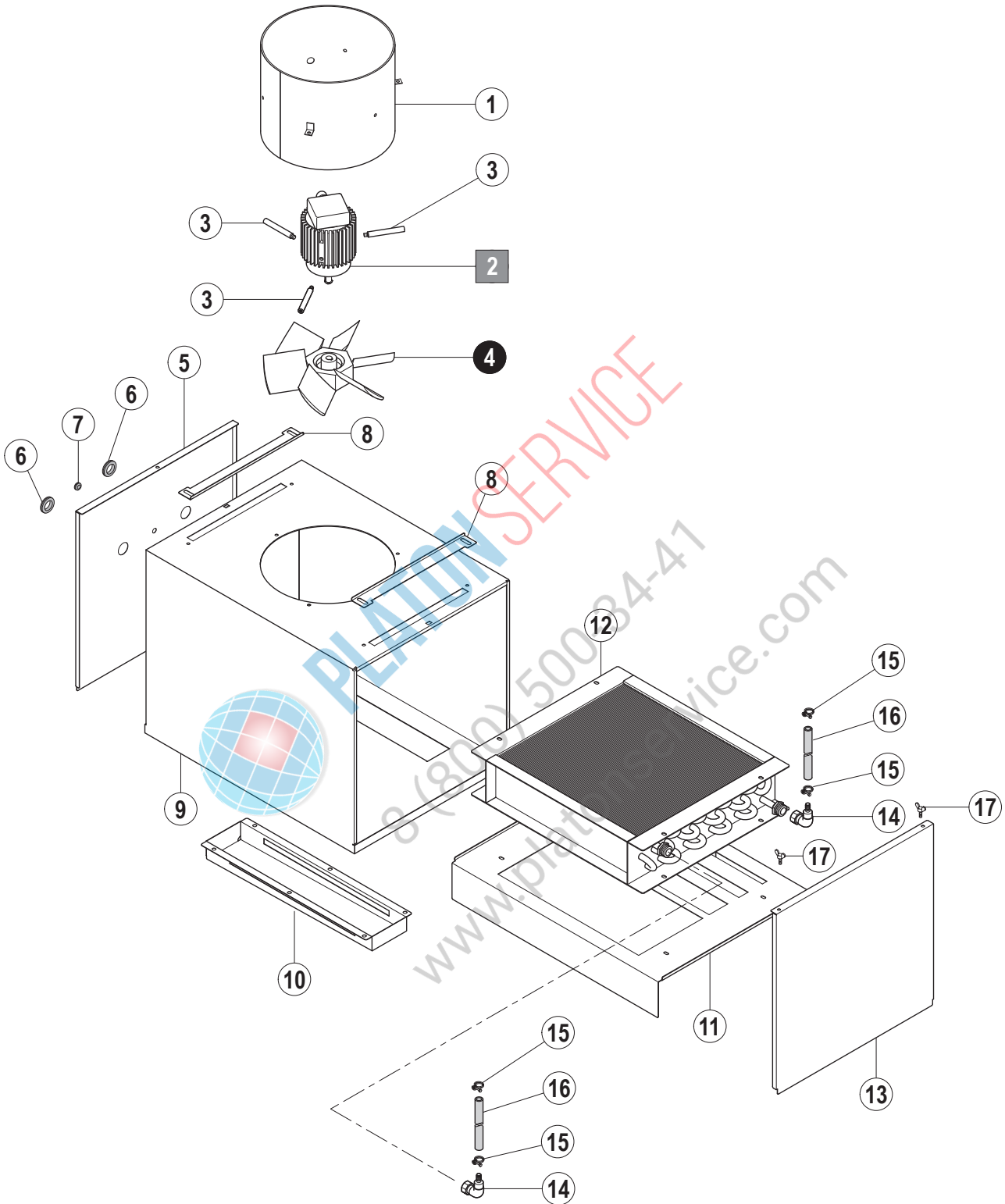

14.2

CN 14.2a



Pos.	A	B			X [mm]	Bemerkung / Remarks / Remarques
		CS	CN	CP		
01		00-229438-001	---	---		
02		00-145075-...	---	---		siehe Schaltplan / see wiring diagram / voir schéma de câblage
03		00-693877-002	---	---		
04		00-038933-001	---	---		
05		01-245206-003	---	---		
06		00-227748-004	---	---		
07		00-227748-001	---	---		
08		00-228336-000	---	---		
09		01-291392-002	---	---		
10		01-291796-001	---	---		
11		01-245274-004	---	---		
12		01-291833-001	---	---		
13		01-245206-001	---	---		
14		00-299240-001	---	---		
15		00-323945-022	---	---		
16		01-245571-002	---	---		L=2000 mm
17		00-609851-000	---	---		



PLATON SERVICE  
8 (800) 500-34-47  
www.platonservice.com

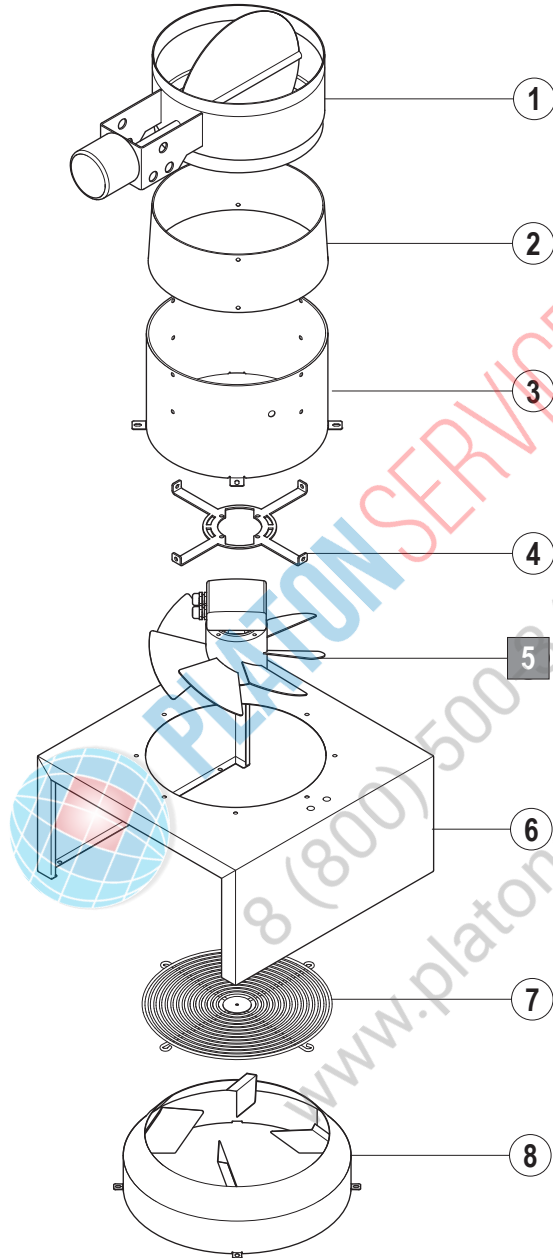

14.3

CN 14.3

Pos.	A	B			X [mm]	Bemerkung / Remarks / Remarques
		CS	CN	CP		
01		---	00-296927-...	=		siehe Schaltplan / see wiring diagram / voir schéma de câblage
02		---	01-245752-001	=		
03		---	01-245746-001	=		
04		---	01-245747-001	=		
05		---	00-775078-...	=		siehe Schaltplan / see wiring diagram / voir schéma de câblage
06		---	01-245745-003	=		
07		---	00-896396-001	=		
08		---	00-781353-001	=		



PLATON SERVICE

8 (800) 500-34-47

www.platonservice.com



**PLATON** SERVICE

8 (800) 500-34-47

[www.platonservice.com](http://www.platonservice.com)



**PLATON**SERVICE

8 (800) 500-34-41

[www.platonservice.com](http://www.platonservice.com)

**CS / CN / CP**

**Wärmepumpe**

**Heat pump**

**Pompe à chaleur**

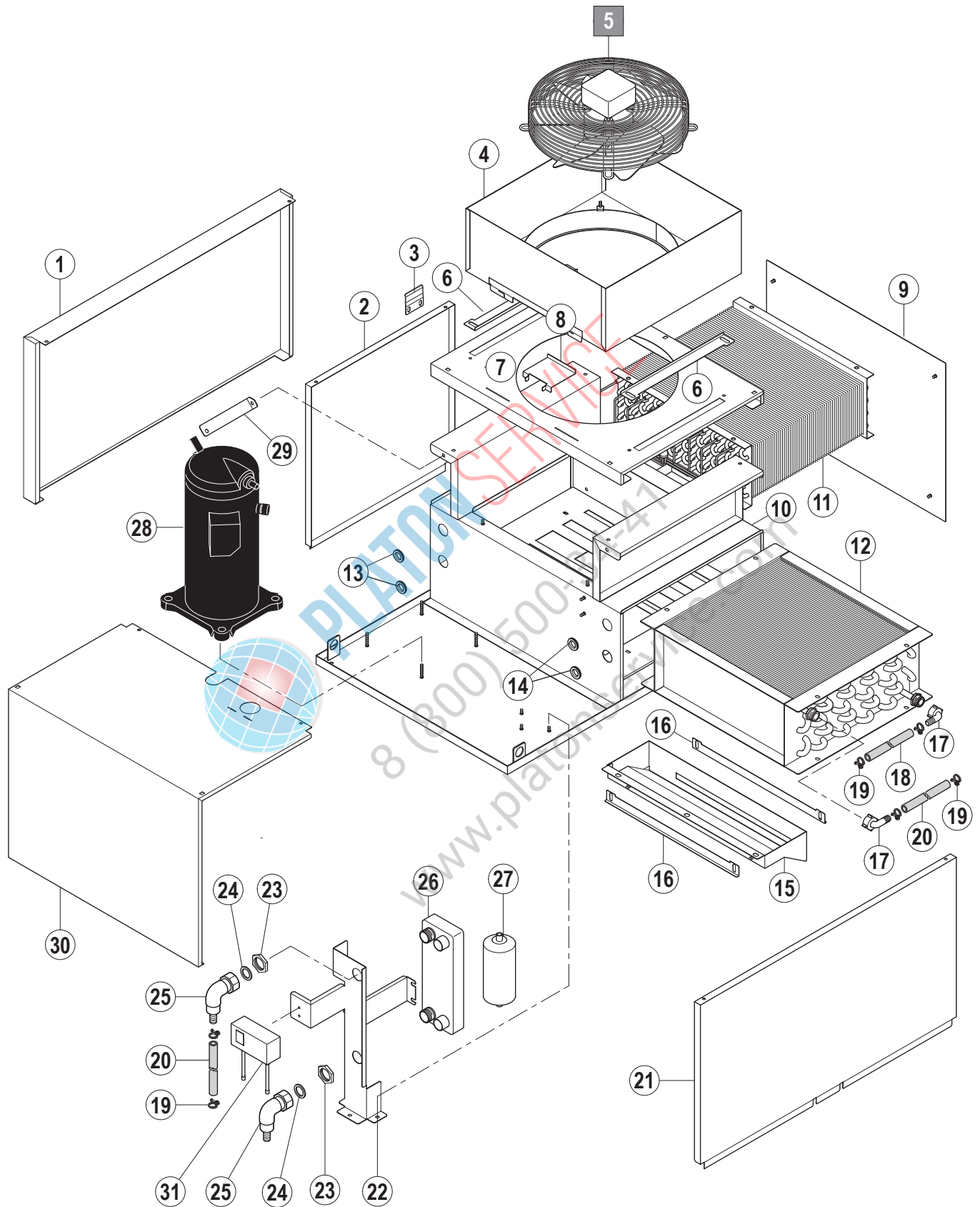

15.1

CN 15.1

Pos.	A	B			X [mm]	Bemerkung / Remarks / Remarques
		CS	CN	CP		
01		---	01-291604-001	=		
02		---	01-296226-001	=		
03		---	01-291605-001	=		
04		---	01-291595-001	=		
05		---	00-781492-...	=		siehe Schaltplan / see wiring diagram / voir schéma de câblage
06		---	01-291395-002	=		
07		---	01-291589-001	=		
08		---	01-291837-001	=		
09		---	01-291593-001	=		
10		---	01-291588-001	=		
11		---	00-887639-001	=		
12		---	01-245490-007	=		
13		---	00-785565-004	=		
14		---	00-227748-004	=		
15	L/R	---	01-291394-001	=		
	R/L	---	01-291394-002	=		
16		---	01-291395-001	=		
17		---	00-299240-001	=		
18		---	01-245571-014	=		L=500 mm
19		---	00-323945-022	=		
20		---	01-245571-002	=		L=2000 mm
21		---	01-245548-001	=		
22		---	01-245549-001	=		
23		---	00-172739-008	=		
24		---	00-168611-003	=		
25		---	01-245560-001	=		
26		---	00-323456-001	=		
27		---	00-323443-000	=		
28		---	00-323437-...	=		siehe Schaltplan / see wiring diagram / voir schéma de câblage
29		---	01-245722-001	=		
30		---	01-291591-001	=		
31		---	01-296704-001	=		

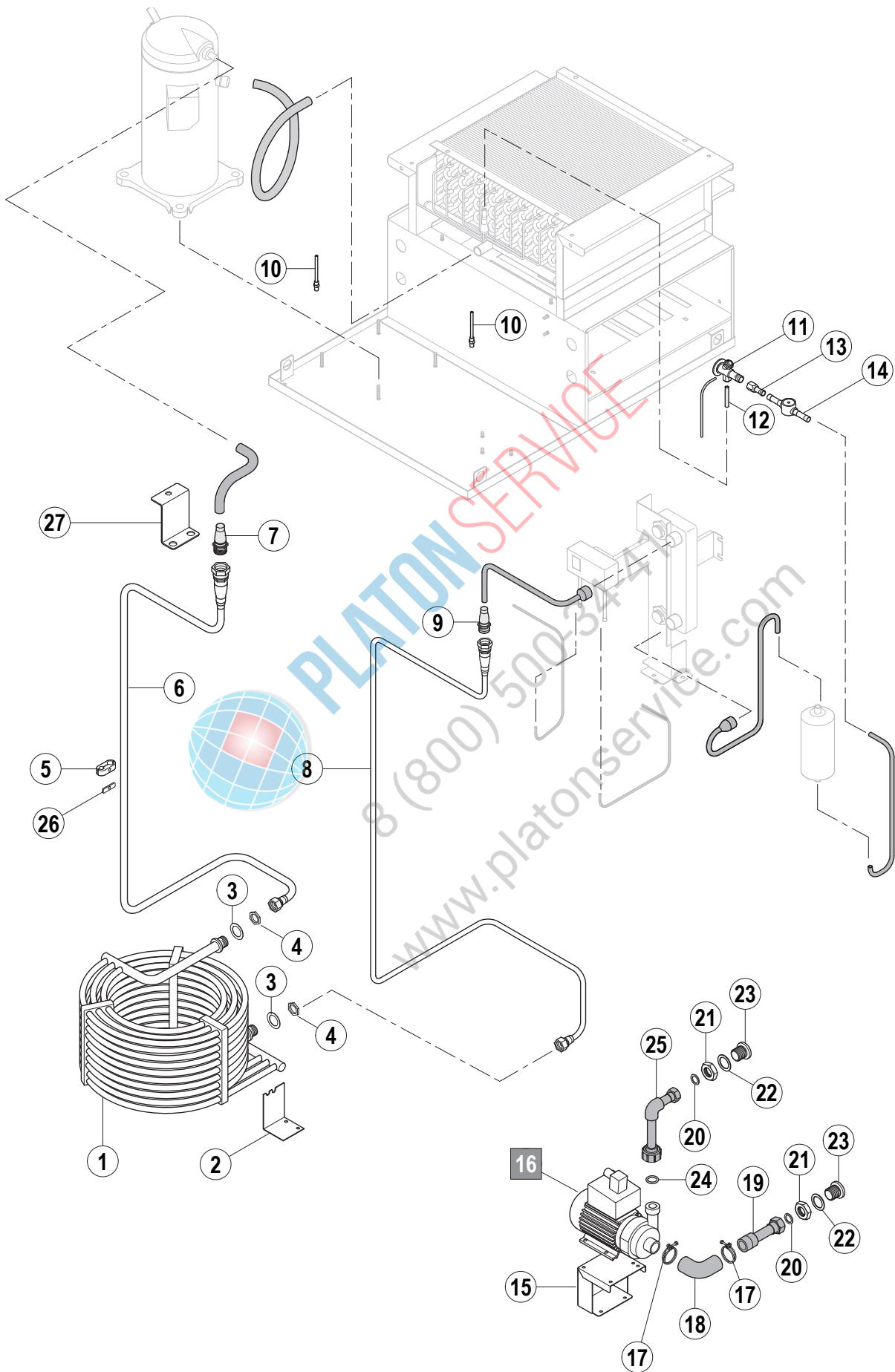

15.2



Pos.	A	B			X [mm]	Bemerkung / Remarks / Remarques
		CS	CN	CP		
01		---	01-291581-001	=		
02		---	01-296021-001	=		
03		---	00-696936-018	=		
04		---	00-172739-013	=		
05		---	00-897282-001	=		
06	L/R	---	01-291598-001	=		
	R/L	---	01-291606-001	=		
07		---	00-896909-001	=		
08	L/R	---	01-291599-001	=		
	R/L	---	01-291607-001	=		
09		---	00-775080-001	=		
10		---	00-323447-000	=		
11		---	00-775082-001	=		
12		---	00-323439-003	=		bei Kompressor ZR-61/ZR48 / with compressor ZR61/ZR48 / chez compresseur ZR61/ZR48
		---	00-323439-004	=		bei Kompressor ZR72 / by compressor ZR72 / chez compresseur ZR72
13		---	00-324439-002	=		
14		---	00-323444-000	=		
15		---	01-296093-002	=		
16		---	00-781237-...	=		siehe Schaltplan / see wiring diagram / voir schéma de câblage
17		---	00-323945-043	=		
18		---	00-781336-004	=		
19		---	01-291664-001	=		
20		---	00-168611-009	=		
21		---	00-603061-000	=		
22		---	00-300084-007	=		
23		---	00-774953-001	=		
24		---	00-067500-072	=		
25	L/R	---	01-291665-001	=		
	R/L	---	01-291665-002	=		
26		---	00-897285-001	=		
27		---	01-296658-001	=		



**PLATON** SERVICE

8 (800) 500-34-47

[www.platonservice.com](http://www.platonservice.com)



**PLATON** SERVICE

8 (800) 500-34-41

[www.platonservice.com](http://www.platonservice.com)

**CS / CN / CP**

**Transportsystem**

**Transport system**

**Système de convoyage**

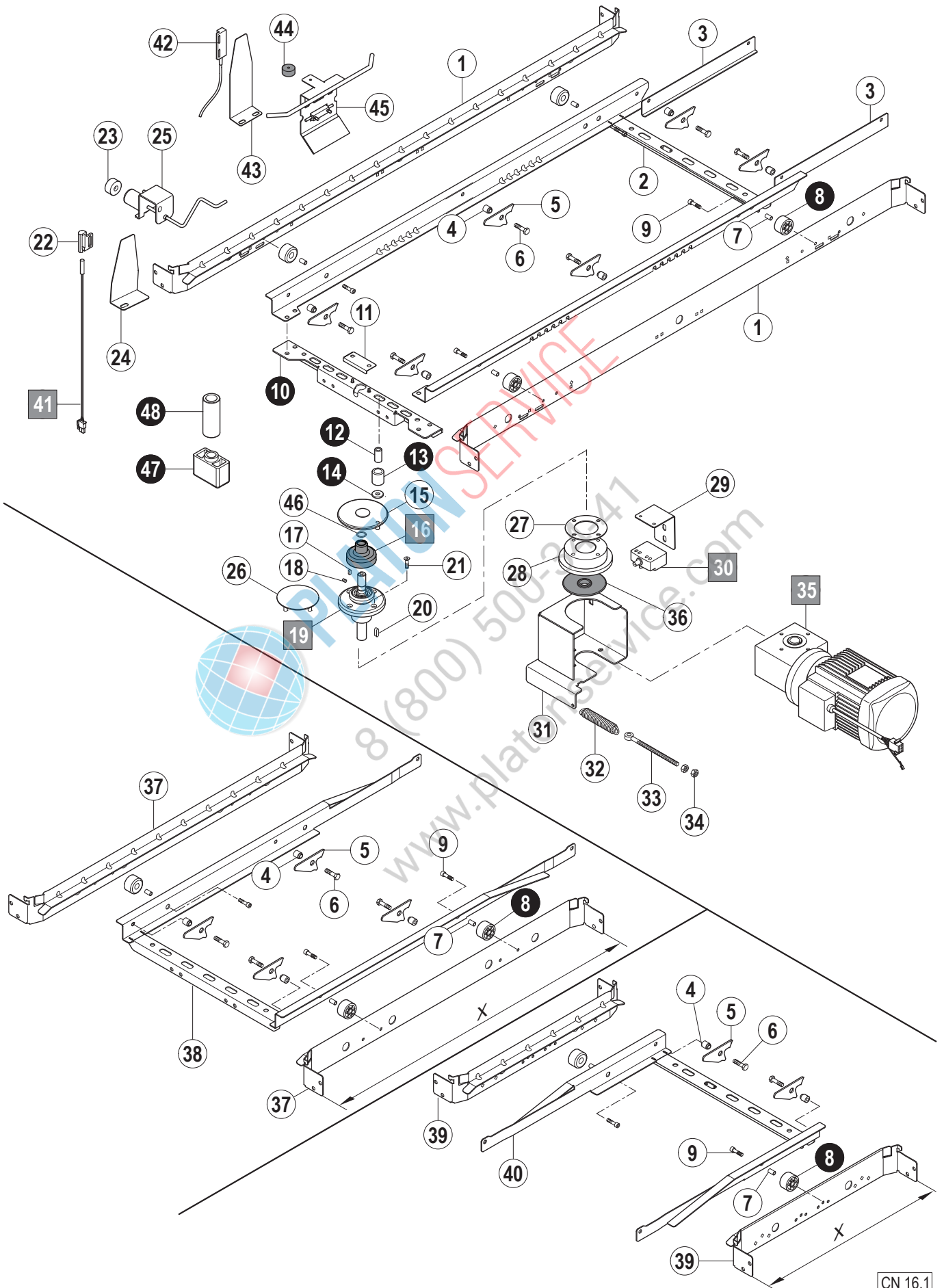

16.1

CN 16.1

Pos.	A	B			X [mm]	Bemerkung / Remarks / Remarques
		CS	CN	CP		
01		01-291368-001	=	=		
02		01-291375-001	=	=		
03		---	01-291881-001	=		SN-Modul
04		01-243284-001	=	=		
05		01-291371-001	=	=		
06		00-602579-000	=	=		
07		01-291535-001	=	=		
08		01-291534-001	=	=		
09		00-603026-000	=	=		
10		01-291772-001	=	=		
11		00-868312-001	=	=		
12		00-154795-000	=	=		
13		00-154789-000	=	=		
14		00-781490-001	=	=		
15		00-781117-001	=	=		
16		01-296445-001	=	=		
17		00-600681-000	=	=		
18		00-600682-000	=	=		
19		00-781064-004	=	=		
20		00-600683-000	=	=		
21		00-609794-000	=	=		
22		---	00-883838-001	=		
23		---	00-774714-001	=		
24		---	01-291513-001	=		
	L/R	---	01-291774-001	=		E-Modul
	R/L	---	01-291774-002	=		E-Modul
25	L/R	---	01-242189-001	=		
	R/L	---	01-242189-002	=		
26		---	00-899210-001	=		SN-Modul
27		00-781007-001	=	=		
28		01-291529-001	=	=		
29		01-291387-001	=	=		
30		00-785286-001	=	=		
31	L/R	01-291888-001	=	=		
	R/L	01-291888-002	=	=		
32		00-774828-002	=	=		
33		00-602920-000	=	=		
34		00-603488-000	=	=		
35		01-291291-...	=	=		siehe Schaltplan / see wiring diagram / voir schéma de câblage
36		01-241802-001	=	=		
37		01-291368-004	=	=	500	E-Modul
		---	01-291368-003	=	650	L-Modul
		---	01-291368-002	=	900	S-Modul
38		01-291375-004	=	=	500	E-Modul
		---	01-291375-003	=	650	L-Modul
		---	01-291375-002	=	900	S-Modul

Pos.	A	B			X [mm]	Bemerkung / Remarks / Remarques
		CS	CN	CP		
39		---	01-291368-005	=	850	CDS /DS
		---	01-291368-006	=	450	ND
		01-291368-003	---	---	650	D- Trocknung / D- dryer / D- séchage
		---	01-291368-009	=	650	Spülmodul / rinse module / module de rinçage
		---	01-291368-004	=	500	Demi-Spülung / Demi rinse / demi rinçage
40		---	01-291375-005	=	850	CDS / DS
		---	01-291375-006	=	450	ND
		01-291375-003	=	=	650	D- Trocknung / D- dryer / D- séchage
		---	01-291375-008	=	650	Spülmodul / rinse module / module de rinçage
		---	01-291375-004	=	500	Demi-Modul / demi module / demi module
41		---	01-240288-001	=		
42		00-229517-000	---	---		
43		01-291804-001	---	---		
44		00-774714-001	---	---		
45		01-291802-001	---	---		
46		00-276903-007	=	=		
47		01-296150-001	=	=		
48		01-296149-001	=	=		



PLATON SERVICE

8 (800) 500-34-47

www.platonservice.com



**PLATON**SERVICE

8 (800) 500-34-41

[www.platonservice.com](http://www.platonservice.com)

**CS / CN / CP**

**Türen und Verkleidungen**

**Doors and panels**

**Portes et panneaux**

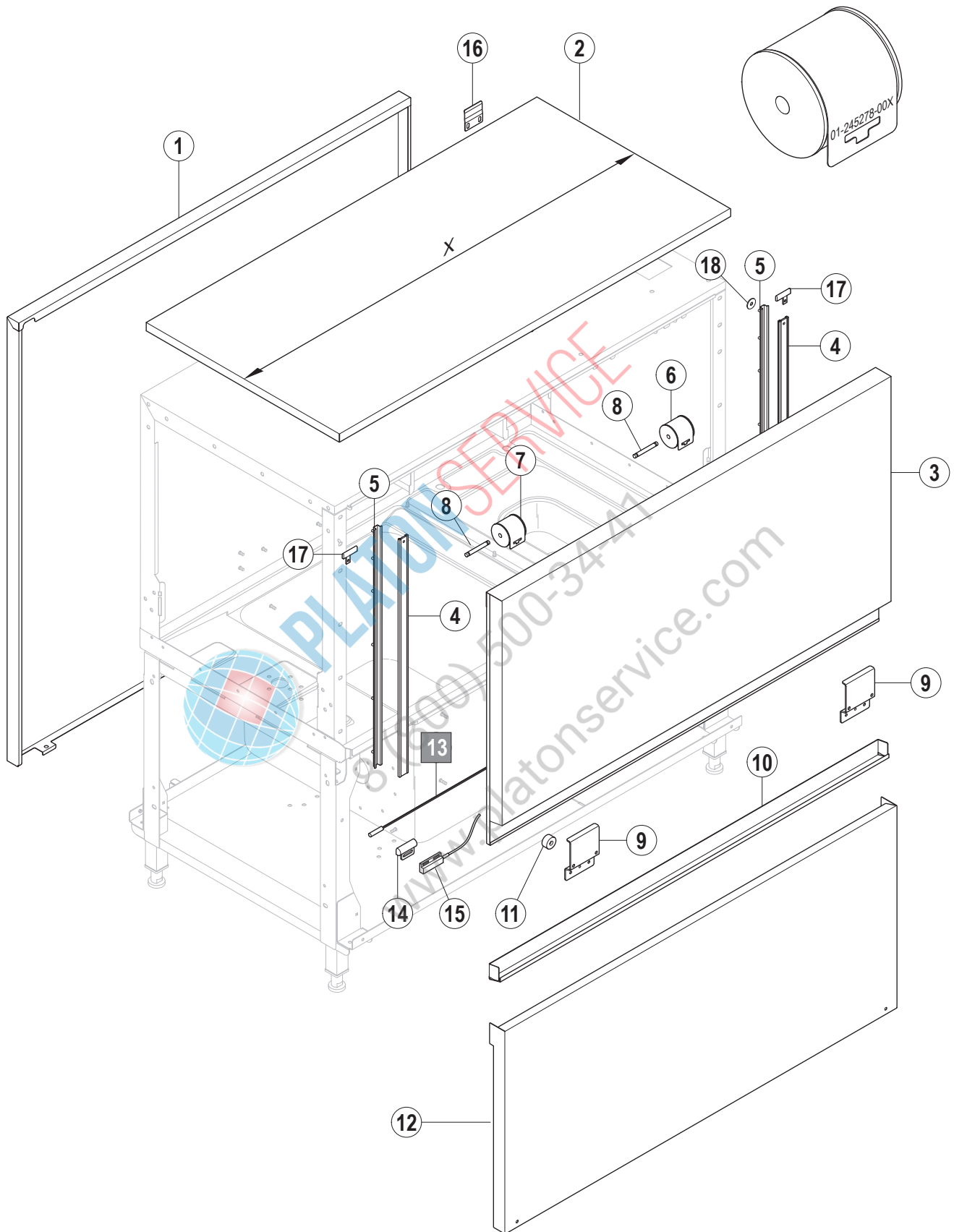



Pos.	A	B			X [mm]	Bemerkung / Remarks / Remarques
		CS	CN	CP		
01		01-291317-005	01-291317-001	---	1350	ohne Isolierung / without insulation / sans isolation
		---	01-291317-002	---	900	ohne Isolierung / without insulation / sans isolation
		---	01-291317-003	---	650	ohne Isolierung / without insulation / sans isolation
		01-291317-006	01-291317-004	---	500	ohne Isolierung / without insulation / sans isolation
		---	01-291317-008	=	300	ohne Isolierung / without insulation / sans isolation
		---	01-291711-001	=	1350	mit Isolierung / with insulation / avec isolation
		---	01-291711-002	=	900	mit Isolierung / with insulation / avec isolation
		---	01-291711-003	=	650	mit Isolierung / with insulation / avec isolation
02		01-291397-010	01-291397-001	---	850	ohne Isolierung / without insulation / sans isolation
		01-291397-002	=	---	900	ohne Isolierung / without insulation / sans isolation
		---	01-291397-003	---	650	ohne Isolierung / without insulation / sans isolation
		01-291397-004	=	---	500	ohne Isolierung / without insulation / sans isolation / E-Modul
		---	01-291397-008	---	500	ohne Isolierung / without insulation / sans isolation / Demi-Modul
		---	01-291397-005	---	450	ohne Isolierung / without insulation / sans isolation
		01-291397-006	=	---	1350	ohne Isolierung / without insulation / sans isolation
		---	01-291397-007	---	300	ohne Isolierung / without insulation / sans isolation
		---	01-291398-001	=	850	mit Isolierung / with insulation / avec isolation
		---	01-291398-002	=	900	mit Isolierung / with insulation / avec isolation
		---	01-291398-003	=	650	mit Isolierung / with insulation / avec isolation
		---	01-291398-004	=	500	mit Isolierung / with insulation / avec isolation / E-Modul
		---	01-291398-008	=	500	mit Isolierung / with insulation / avec isolation / Demi-Modul
		---	01-291398-005	=	450	mit Isolierung / with insulation / avec isolation
03		01-291320-005	---	---	1350	ohne Isolierung / without insulation / sans isolation
		01-291321-001	=	=	1350	mit Isolierung / with insulation / avec isolation
		---	01-291321-002	=	900	mit Isolierung / with insulation / avec isolation
		---	01-291321-003	=	650	mit Isolierung / with insulation / avec isolation
		---	01-291321-004	=	500	mit Isolierung / with insulation / avec isolation
	04	00-325064-008	=	=		
	05	01-245126-003	=	=		
06		01-245278-004	---	---	1350	Tür ohne Isolierung / door without insulation / porte sans isolation
		01-245278-007	=	=	1350	Tür mit Isolierung / door with insulation / porte avec isolation
		---	01-245278-005	=	900	Tür mit Isolierung / door with insulation / porte avec isolation
		---	01-245278-003	=	650	Tür mit Isolierung / door with insulation / porte avec isolation
		---	01-245278-002	=	500	Tür mit Isolierung / door with insulation / porte avec isolation
07		01-245278-003	---	---	1350	Tür ohne Isolierung / door without insulation / porte sans isolation
		01-245278-006	=	=	1350	Tür mit Isolierung / door with insulation / porte avec isolation
		---	01-245278-005	=	900	Tür mit Isolierung / door with insulation / porte avec isolation
		---	01-245278-003	=	650	Tür mit Isolierung / door with insulation / porte avec isolation
		---	01-245278-002	=	500	Tür mit Isolierung / door with insulation / porte avec isolation
08	01-245281-001	=	=			
09		01-245127-001	=	=	1350	
		---	01-245127-001	=	900	
		---	01-245127-003	=	650	
		---	01-245279-001	=	500	

Pos.	A	B			X [mm]	Bemerkung / Remarks / Remarques
		CS	CN	CP		
10		01-245129-005	=	=	1350	
		---	01-245129-002		900	
		---	01-245129-006		650	
		---	01-245129-004		500	
11		00-774714-001	=	=		
12	L/R	01-291787-001	---	---	1350	
	R/L	01-291787-002	---	---	1350	
		---	01-291787-004	----	1350	ohne Vorwaschung / without prewash / sans pré lavage
	L/R	---	01-291787-005	01-291407-010	1350	mit Vorwaschung / with prewash / avec pré lavage
	R/L	---	01-291787-006	01-291407-010	1350	mit Vorwaschung / with prewash / avec pré lavage
	L/R	---	01-291407-004	=	900	S- Modul
	R/L	---	01-291407-005	=	900	S- Modul
		---	01-291407-011	=	900	A- Modul
	L/R	---	01-291407-006		650	L-Modul
	R/L	---	01-291407-007		650	L-Modul
		---	01-291407-008		650	Spülmodul / rinse module / module de rinçage
	L/R	---	01-291407-009	---	500	Demi-Modul / Demi module / Demi module
	R/L	---	01-291407-015	---	500	Demi-Modul / Demi module / Demi module
			---	01-291407-016	---	500
13		---	01-240288-001	---		
14		---	00-883838-001	---		
15		00-229517-000	---	---		
16		01-291605-001	=	=		
17		01-291426-001	=	=		
18		00-696936-066	=	=		



**PLATON** SERVICE

8 (800) 500-34-41

[www.platonservice.com](http://www.platonservice.com)

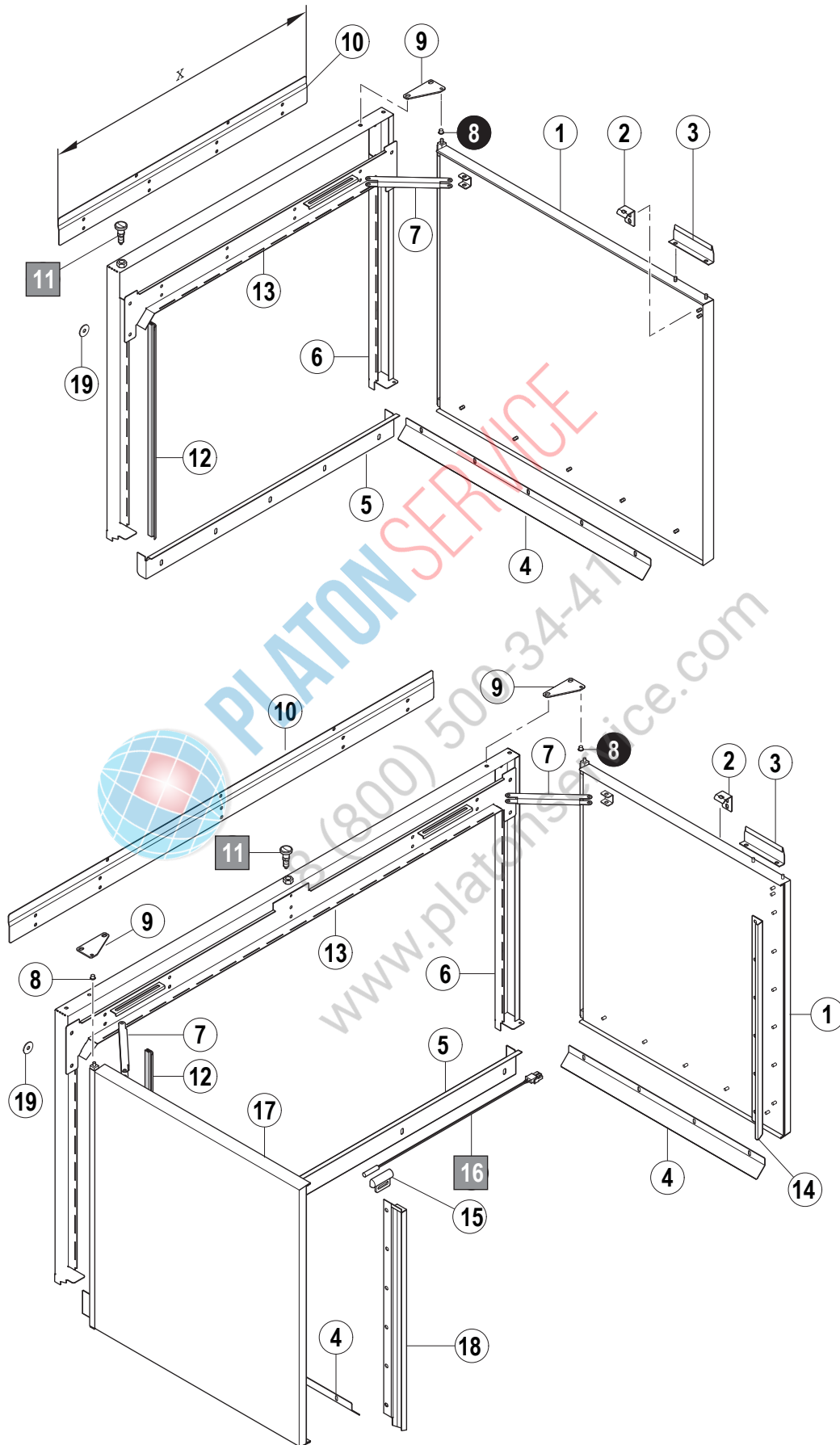

17.2

Pos.	A	B			X [mm]	Bemerkung / Remarks / Remarques
		CS	CN	CP		
01		01-245985-011	=	=	500	
		01-245985-012	=	=	650	
		01-245985-013	=	=	900	
		01-245985-014	=	=	1350	
02		01-247015-002	=	=		
03		00-896817-002	=	=		
04		01-243888-001	=	=	500	
		01-243888-002	=	=	650	
		01-243888-004	=	=	900	
		01-243888-014	=	=	1350	
05		01-245988-003	=	=	500	
		01-245988-002	=	=	650	
		01-245988-001	=	=	900	
		01-245988-006	=	=	1350	
06		01-291979-003	=	=	500	
		01-291979-002	=	=	650	
		01-291979-001	=	=	900	
		01-291979-004	=	=	1350	
07		01-245990-001	=	=		
08		00-298963-014	=	=		
09		00-784243-001	=	=		
10		01-291062-003	=	=	500	
		01-291062-002	=	=	650	
		01-291062-001	=	=	900	
		01-291062-006	=	=	1350	
11		01-247013-001	=	=		
12		01-243873-015	=	=		L=1700 mm
		01-243873-017	=	=		L=2100 mm
		01-243873-021	=	=		L=2600 mm
13		01-245987-003	=	=	500	
		01-245987-002	=	=	650	
		01-245987-001	=	=	900	
		01-245987-006	=	=	1350	
14		01-245996-004	=	=		
15		---	01-240288-001	=		
16		---	00-883838-001	=		
17		01-245985-015	=	=		
18		01-291111-004	=	=		
19		00-696936-066	=	=		



**PLATON** SERVICE

8 (800) 500-34-47

[www.platonservice.com](http://www.platonservice.com)



**PLATON**SERVICE

8 (800) 500-34-41

[www.platonservice.com](http://www.platonservice.com)

**CS / CN / CP**

**Trocknung – gerade**

**Dryer – straight**

**Séchage – droit**

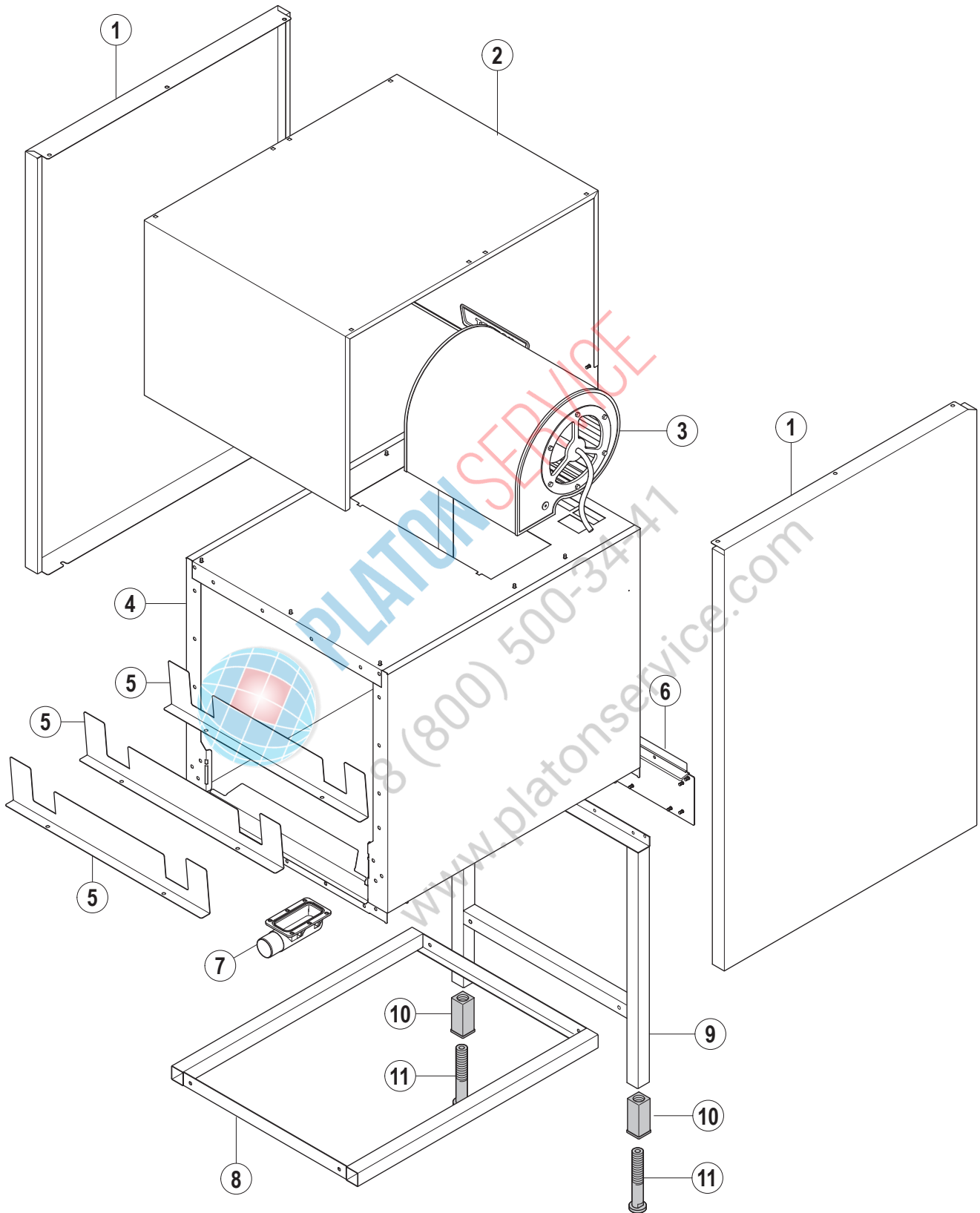

18.1

CN 18.1



Pos.	A	B			X [mm]	Bemerkung / Remarks / Remarques
		CS	CN	CP		
01		01-291462-002	01-291462-001	---		ohne Isolierung / without insulation / sans isolation
		01-291828-002	01-291828-001	---		mit Isolierung / with insulation / avec isolation
02		01-291453-002	01-291453-001	---		
03		00-897700-...	=	---		siehe Schaltplan / see wiring diagram / voir schéma de câblage
04		01-291451-004	01-291451-001	---		
05		01-291713-001	=	---		
06		01-291429-002	=	---		
07		00-325529-001	=	---		
08		00-378747-377	00-378747-186	---		
09		00-734997-001	=	---		
10		00-325008-001	=	---		
11		00-325007-001	=	---		



PLATON SERVICE

8 (800) 500-34-47

www.platonservice.com

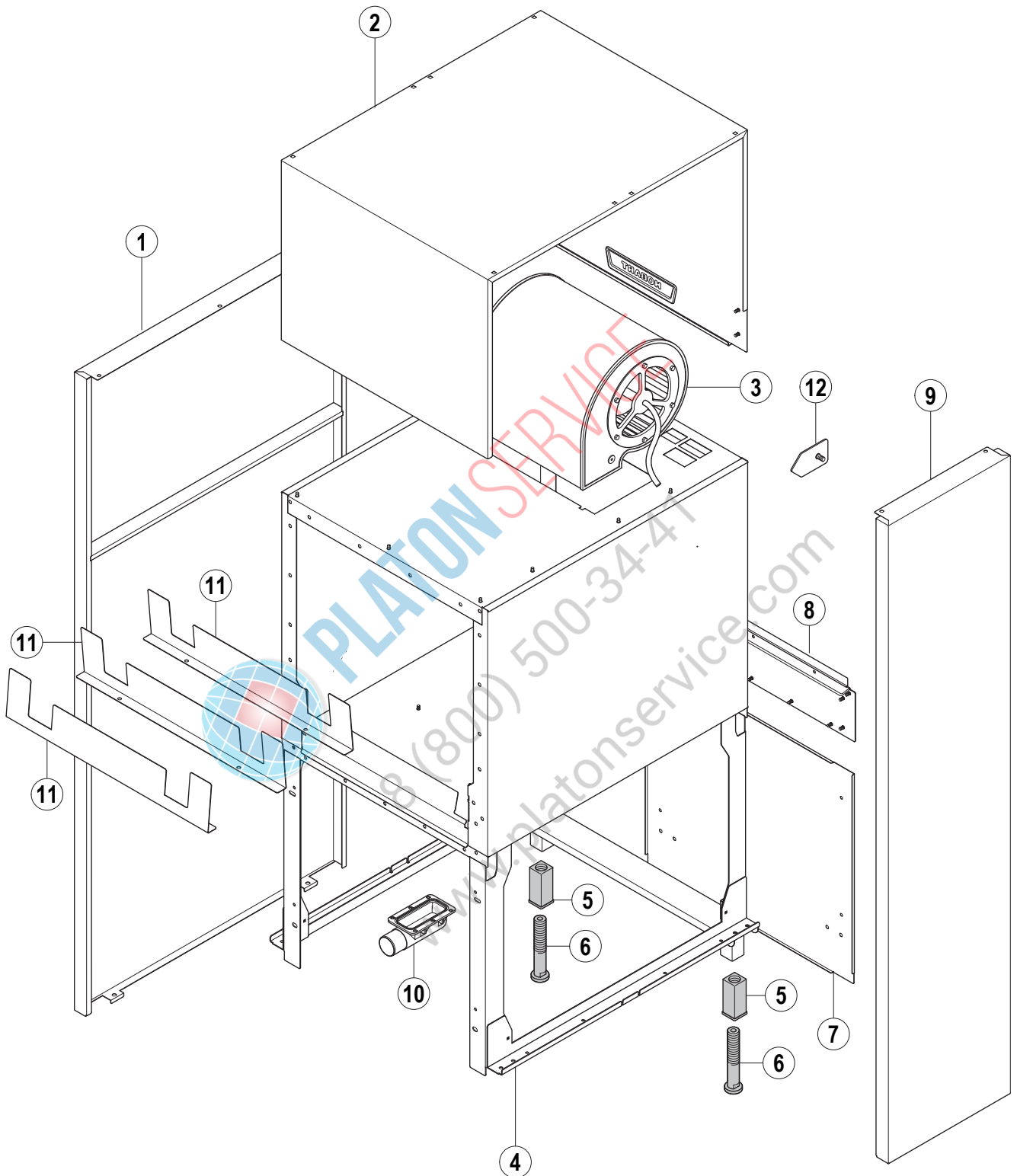

18.2

Pos.	A	B			X [mm]	Bemerkung / Remarks / Remarques
		CS	CN	CP		
01		---	01-291467-001	=		ohne Isolierung / without insulation / sans isolation
		---	01-291829-001	=		mit Isolierung / with insulation / avec isolation
02		---	01-291453-001	=		
03		---	00-897700-...	=		siehe Schaltplan / see wiring diagram / voir schéma de câblage
04		---	01-291518-001	=		
05		---	00-325008-001	=		
06		---	00-325007-001	=		
07		---	01-291419-003	=		
08		---	01-291429-002	=		
09		---	01-291467-002	=		ohne Isolierung / without insulation / sans isolation
		---	01-291829-002	=		mit Isolierung / with insulation / avec isolation
10		---	00-325529-001	=		
11		---	01-291713-001	=		
12		---	01-296621-001	=		



PLATON SERVICE  
8 (800) 500-34-47  
www.platonservice.com

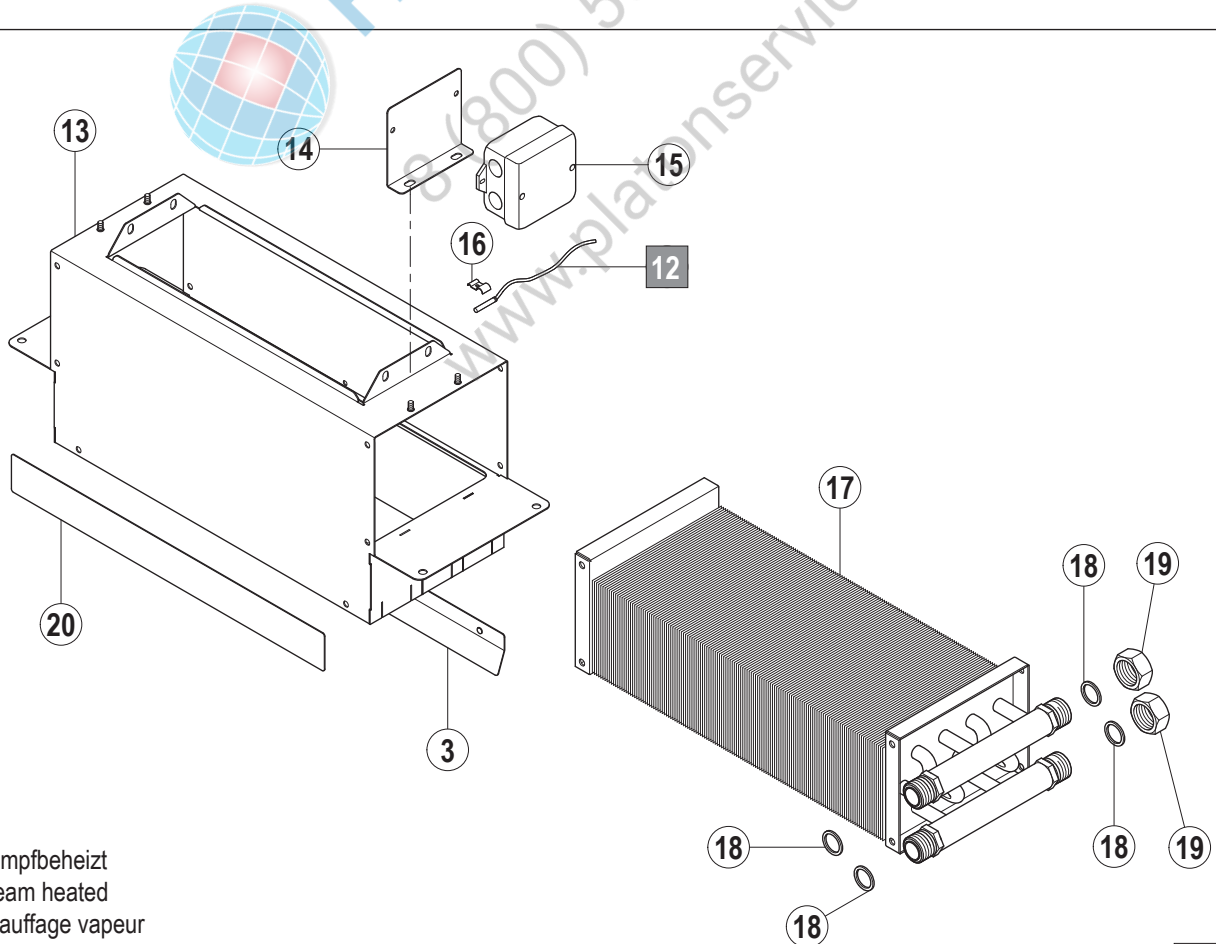
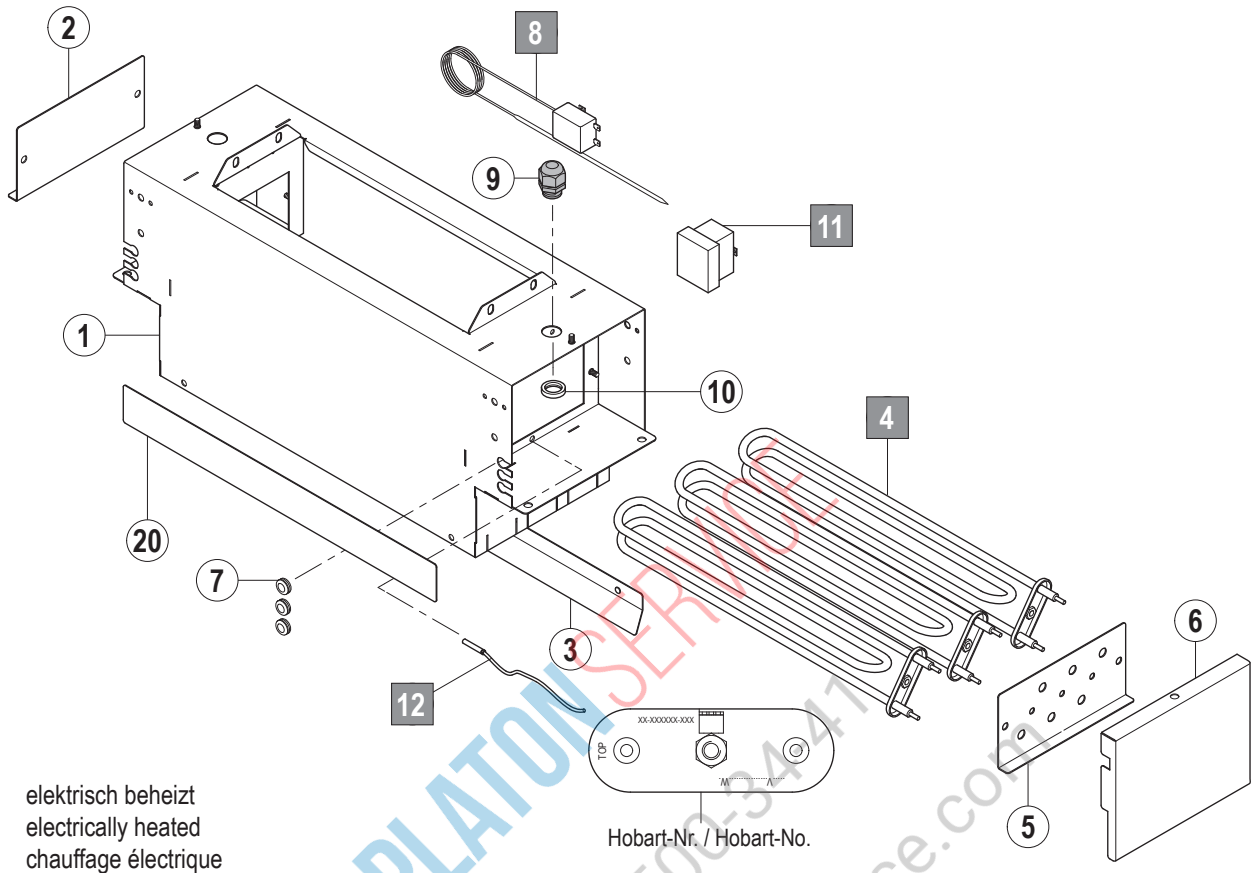

18.3

Pos.	A	B			X [mm]	Bemerkung / Remarks / Remarques
		CS	CN	CP		
01		01-291465-001	=	=		
02		01-245214-004	=	=		
03		01-245557-005	=	=		
04		00-229189-...	=	=		Nr. siehe Flansch / no. see flange / no. voir bride
05		01-245554-002	=	=		
06		01-291463-001	=	=		
07		00-227748-001	=	=		
08		00-226505-001	---	---		
09		00-695661-003	=	=		
10		00-695665-003	=	=		
11		00-378791-000	=	=		
12		---	00-775612-001	=		
13		---	01-291894-001	=		
14		---	01-291974-001	=		
15		---	00-232633-000	=		
16		---	00-324157-000	=		
17		---	01-291895-001	=		
18		---	00-302574-014	=		
19		---	01-245605-001	=		
20		---	01-296197-001	=		nur CDC / only CDC / seulement CDC



PLATON SERVICE  
8 (800) 500-3447  
www.platonservice.com



**PLATON**SERVICE

8 (800) 500-34-47

[www.platonservice.com](http://www.platonservice.com)



**PLATON**SERVICE

8 (800) 500-34-41

[www.platonservice.com](http://www.platonservice.com)

**CS / CN / CP**

**Transportkurven**

**Transport curves**

**Convoyage d'angle**

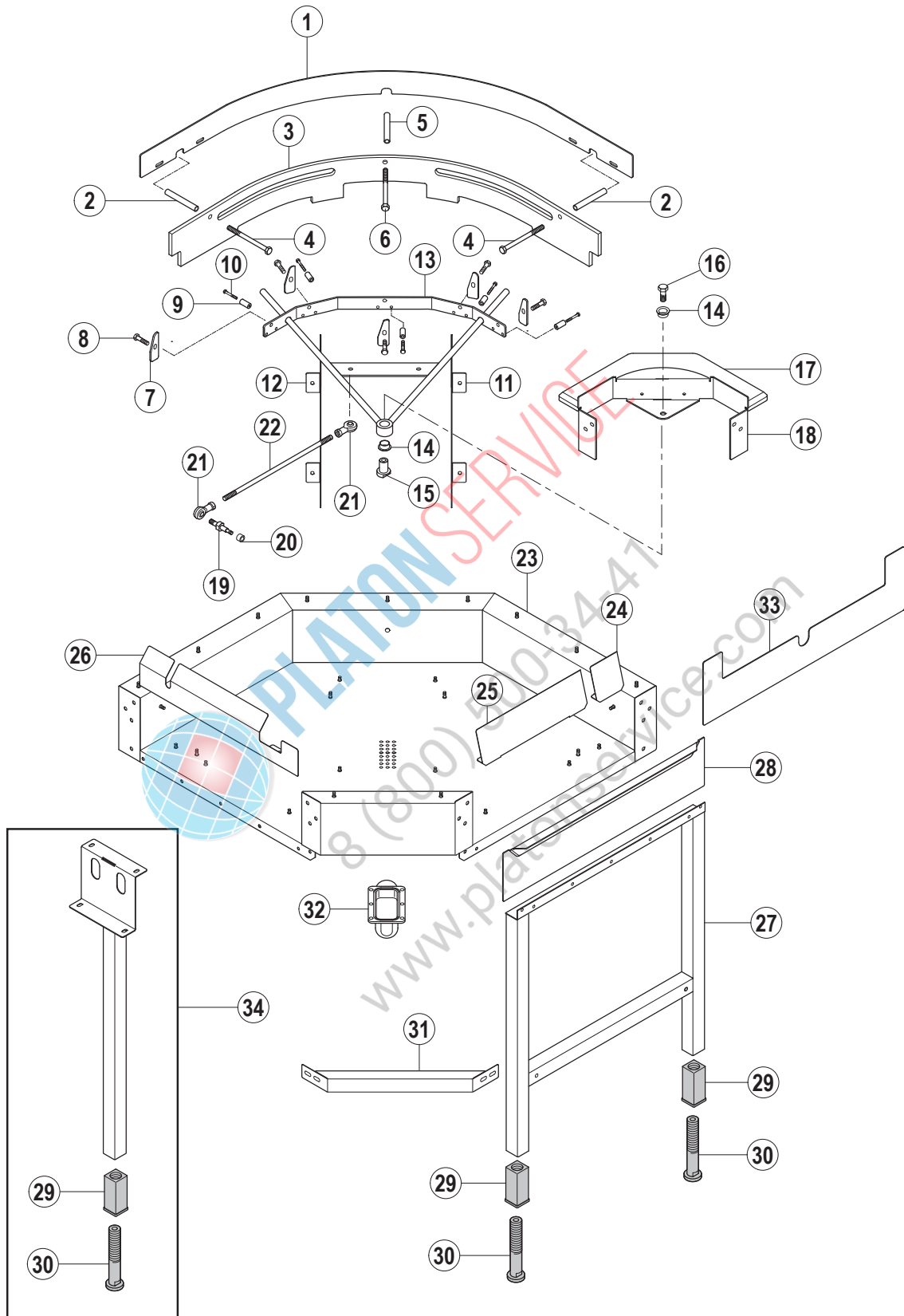

19.1

CN 19.1



Pos.	A	B			X [mm]	Bemerkung / Remarks / Remarques
		CS	CN	CP		
01		00-896433-001	=	=		
02		00-866524-003	=	=		
03		00-896431-001	=	=		
04		00-603124-000	=	=		
05		00-866524-002	=	=		
06		00-604059-000	=	=		
07		00-897777-001	=	=		
08		00-609312-000	=	=		
09		00-380528-037	=	=		
10		00-602643-000	=	=		
11		00-897727-001	=	=		
12		00-897727-002	=	=		
13		00-896440-001	=	=		
14		00-298963-012	=	=		
15		00-734988-001	=	=		
16		00-602594-000	=	=		
17		00-897769-001	=	=		
18		01-291724-001	=	=		
19		00-884105-001	=	=		
20		01-243284-002	=	=		
21		00-609067-000	=	=		
22		00-884128-009	=	=		L=360 mm
		00-884128-010	=	=		L=480 mm
23		01-291719-001	=	=		ohne Trocknung / without dryer / sans séchage
		01-291719-002	=	=		mit Trocknung / with dryer / avec séchage
24		00-897738-002	=	=		
25		00-897738-001	=	=		
26	L/R	01-242184-001	=	=		
	R/L	01-242184-002	=	=		
27		00-734997-001	=	=		
28		01-291429-002	=	=		
29		00-325008-001	=	=		
30		00-325007-001	=	=		
31		00-899284-001	=	=		
32		00-325529-001	=	=		
33		01-291759-001	=	=		
34		00-896438-001	=	=		

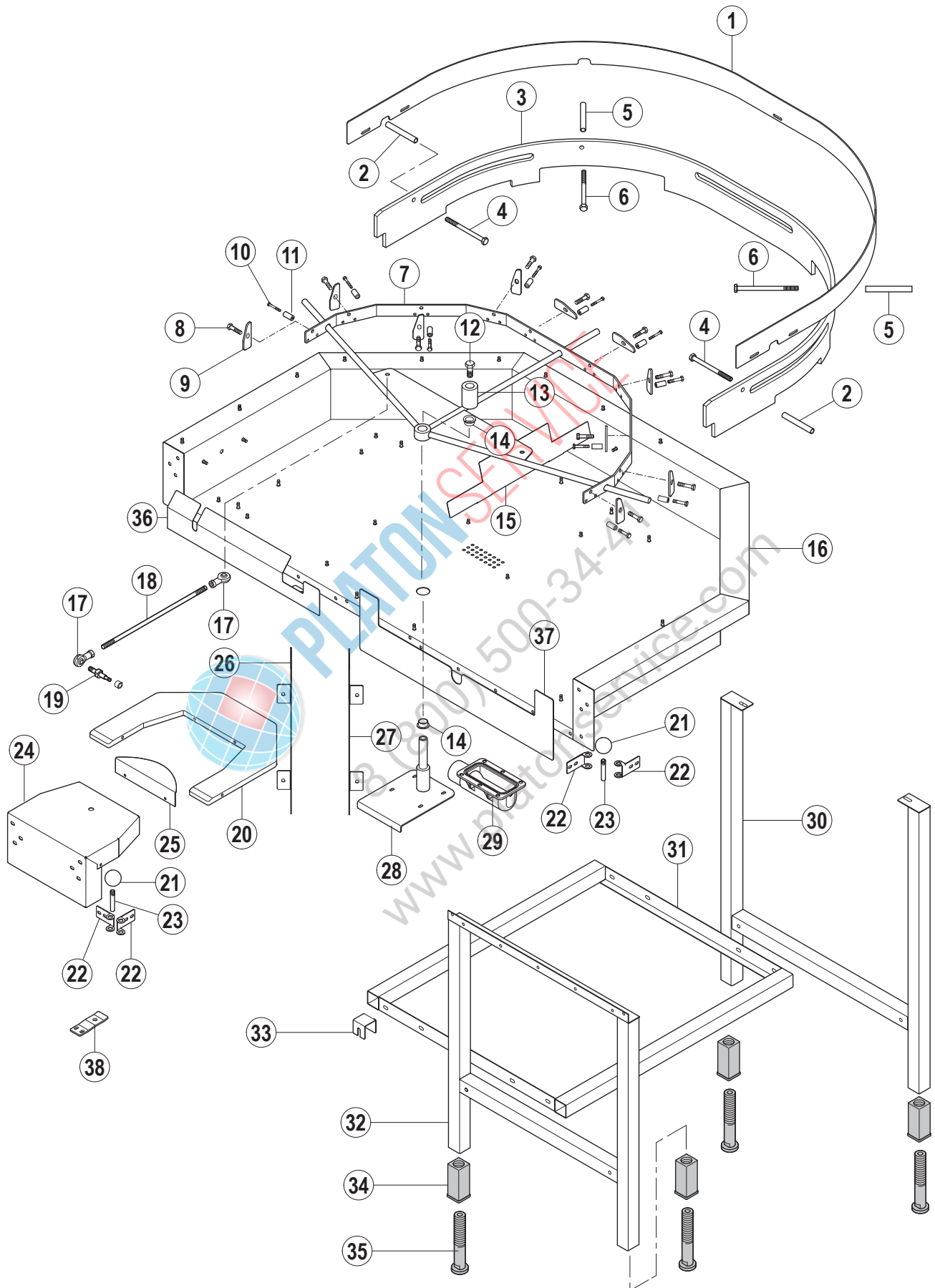

Pos.	A	B			X [mm]	Bemerkung / Remarks / Remarques
		CS	CN	CP		
01		01-245225-001	=	=		
02		00-866524-003	=	=		
03		01-243213-001	=	=		
04		00-603124-000	=	=		
05		00-866524-002	=	=		
06		00-604-059-000	=	=		
07		01-243216-001	=	=		
08		00-609312-000	=	=		
09		00-897777-001	=	=		
10		00-602573-000	=	=		
11		00-380528-037	=	=		
12		00-602594-000	=	=		
13		01-243217-001	=	=		
14		00-298963-012	=	=		
15		01-243234-001	=	=		
16	L/R	01-291762-001	=	=		ohne Trocknung / without dryer / sans séchage
	R/L	01-291762-002	=	=		ohne Trocknung / without dryer / sans séchage
	L/R	01-291762-003	=	=		mit Trocknung / with dryer / avec séchage
	R/L	01-291762-004	=	=		mit Trocknung / with dryer / avec séchage
17		00-609067-000	=	=		
18		00-884128-009	=	=		L=360 mm
19		00-884105-001	=	=		
20		01-243214-001	=	=		
21		00-603618-000	=	=		
22		01-243233-001	=	=		
23		00-735094-001	=	=		
24		01-291763-001	=	=		
25		01-243229-001	=	=		
26		00-897727-002	=	=		
27		00-897727-001	=	=		
28		01-243220-001	=	=		
29		00-325529-001	=	=		
30		00-896477-001	=	=		
31		01-243230-001	=	=		
32		00-734997-001	=	=		
33		00-895610-001	=	=		
34		00-325008-001	=	=		
35		00-325007-001	=	=		
36	L/R	01-242184-001	=	=		
	R/L	01-242184-002	=	=		
37		01-291759-001	=	=		
38		01-296169-001	=	=		nur bei CDC-C/CTC-C an ND-Modul / only with CDC-C/CTC-C in ND-module / seulement à CDC-C/CTC-C au module ND

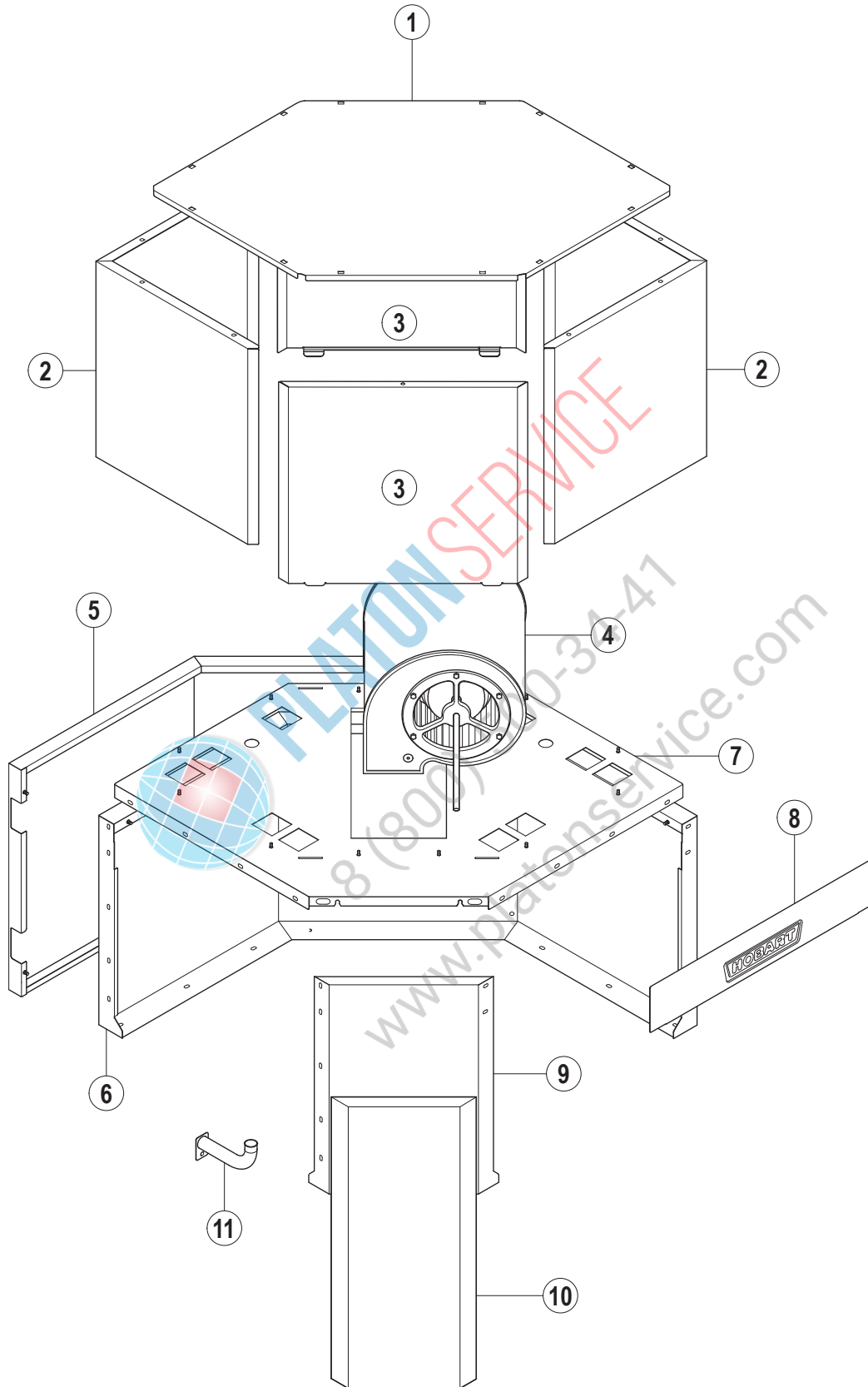

Pos.	A	B			X [mm]	Bemerkung / Remarks / Remarques
		CS	CN	CP		
01		01-291734-001	=	=		
02		01-291732-001	=	=		
03		01-291735-001	=	=		
04		00-897700-...	=	=		siehe Schaltplan / see wiring diagram / voir schéma de câblage
05		01-291737-001	=	=		
06	L/R	01-291726-001	=	=		
	R/L	01-291726-002	=	=		
07		01-291728-001	=	=		
08		01-291497-002	=	=		
09	L/R	01-291731-001	=	=		CDC91
	R/L	01-291731-002	=	=		CDC91
	L/R	01-291765-001	=	=		CDC181-C
	R/L	01-291765-002	=	=		CDC181-C
10		01-291756-001	=	=		CDC91
		01-291841-001	=	=		CDC181-C
11		01-291754-001	=	=		



**PLATON SERVICE**  
8 (800) 500-34-47  
www.platonservice.com



**PLATON**SERVICE

8 (800) 500-34-47

[www.platonservice.com](http://www.platonservice.com)



**PLATON**SERVICE

8 (800) 500-34-41

[www.platonservice.com](http://www.platonservice.com)

**CS / CN / CP**

**Dampfverrohrung**

**Steam piping**

**Tuyauterie vapeur**

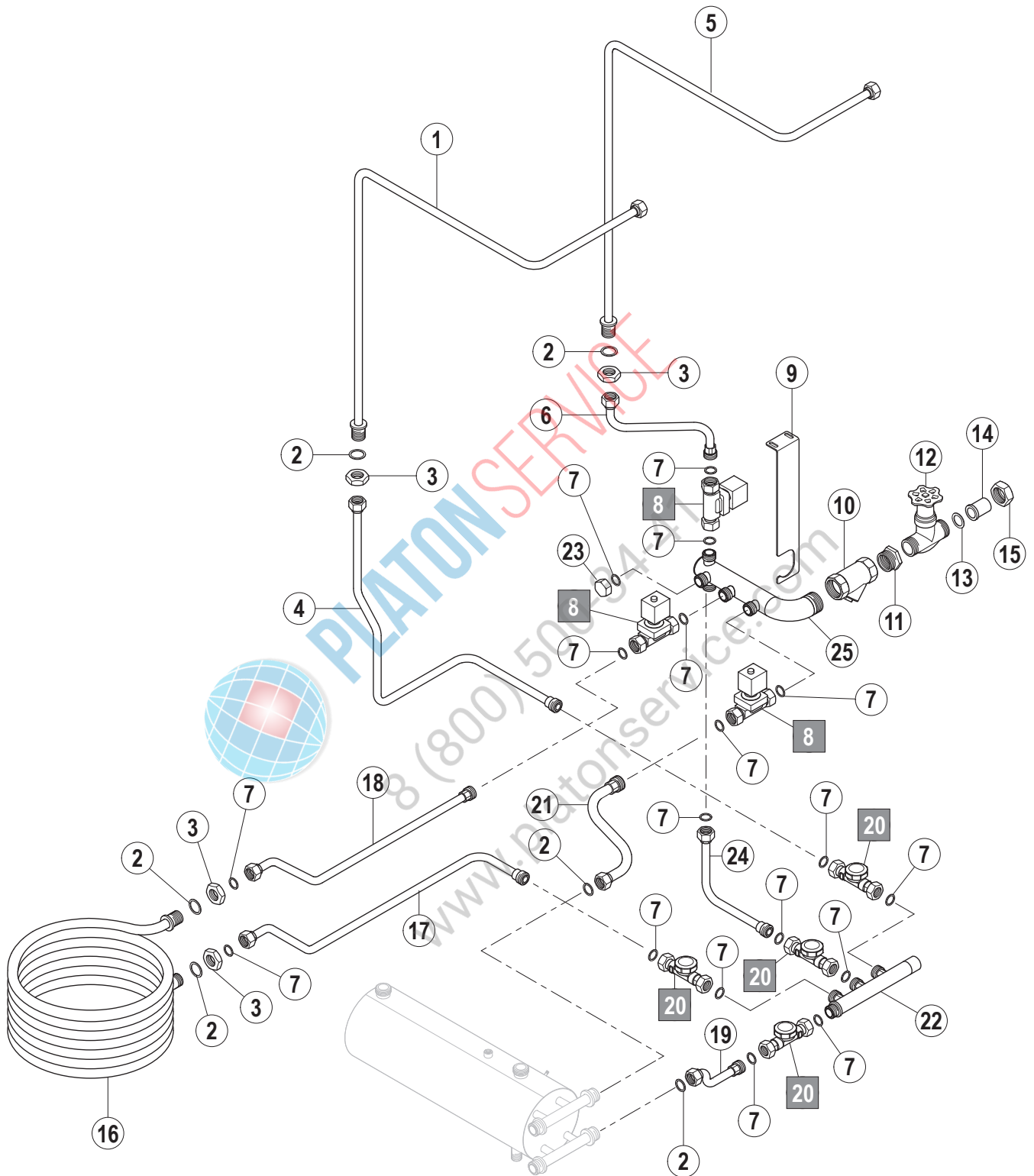



Pos.	A	B			X [mm]	Bemerkung / Remarks / Remarques
		CS	CN	CP		
01	L/R	---	01-291891-001	---		mit CDS-Trockung / with CDS dryer / avec séchage CDS
	R/L	---	01-291891-003	---		mit CDS-Trockung / with CDS dryer / avec séchage CDS
	L/R	---	01-291897-001	---		mit CDC-Trockung / with CDC dryer / avec séchage CDC
	R/L	---	01-291897-003	---		mit CDC-Trockung / with CDC dryer / avec séchage CDC
02		---	00-304084-010	---		
03		---	00-609698-000	---		
04	L/R	---	01-291919-001	---		mit CDS-Trockung / with CDS dryer / avec séchage CDS
	R/L	---	01-291932-001	---		mit CDS-Trockung / with CDS dryer / avec séchage CDS
	L/R	---	01-291919-002	---		mit CDC-Trockung / with CDC dryer / avec séchage CDC
	R/L	---	01-291932-002	---		mit CDC-Trockung / with CDC dryer / avec séchage CDC
05	L/R	---	01-291891-002	---		mit CDS-Trockung / with CDS dryer / avec séchage CDS
	R/L	---	01-291891-004	---		mit CDS-Trockung / with CDS dryer / avec séchage CDS
	L/R	---	01-291897-002	---		mit CDC-Trockung / with CDC dryer / avec séchage CDC
	R/L	---	01-291897-004	---		mit CDC-Trockung / with CDC dryer / avec séchage CDC
06		---	01-2919907-001	---		mit CDS-Trockung / with CDS dryer / avec séchage CDS
		---	01-2919907-002	---		mit CDC-Trockung / with CDC dryer / avec séchage CDC
07		---	00-302574-014	---		
08		---	01-245593-001	---		Dampf / steam / vapeur 1 - 3,5 bar
		---	01-245593-002	---		Dampf / steam / vapeur <= 1 bar
09		---	01-291929-001	---		
10		---	00-774429-001	---		
11		---	00-609276-000	---		
12		---	00-165829-102	---		
13		---	00-300084-007	---		
14		---	00-846944-002	---		
15		---	00-609460-000	---		
16		---	01-245647-002	---		
17	L/R	---	01-291917-001	---		
	R/L	---	01-291917-002	---		
18		---	01-291905-001	---		
19		---	01-291915-001	---		
20		---	01-245603-002	---		
21		---	01-291899-001	---		
22		---	01-291912-001	---		
23		---	01-245605-001	---		
24		---	01-291909-001	---		
25		---	01-291902-001	---		

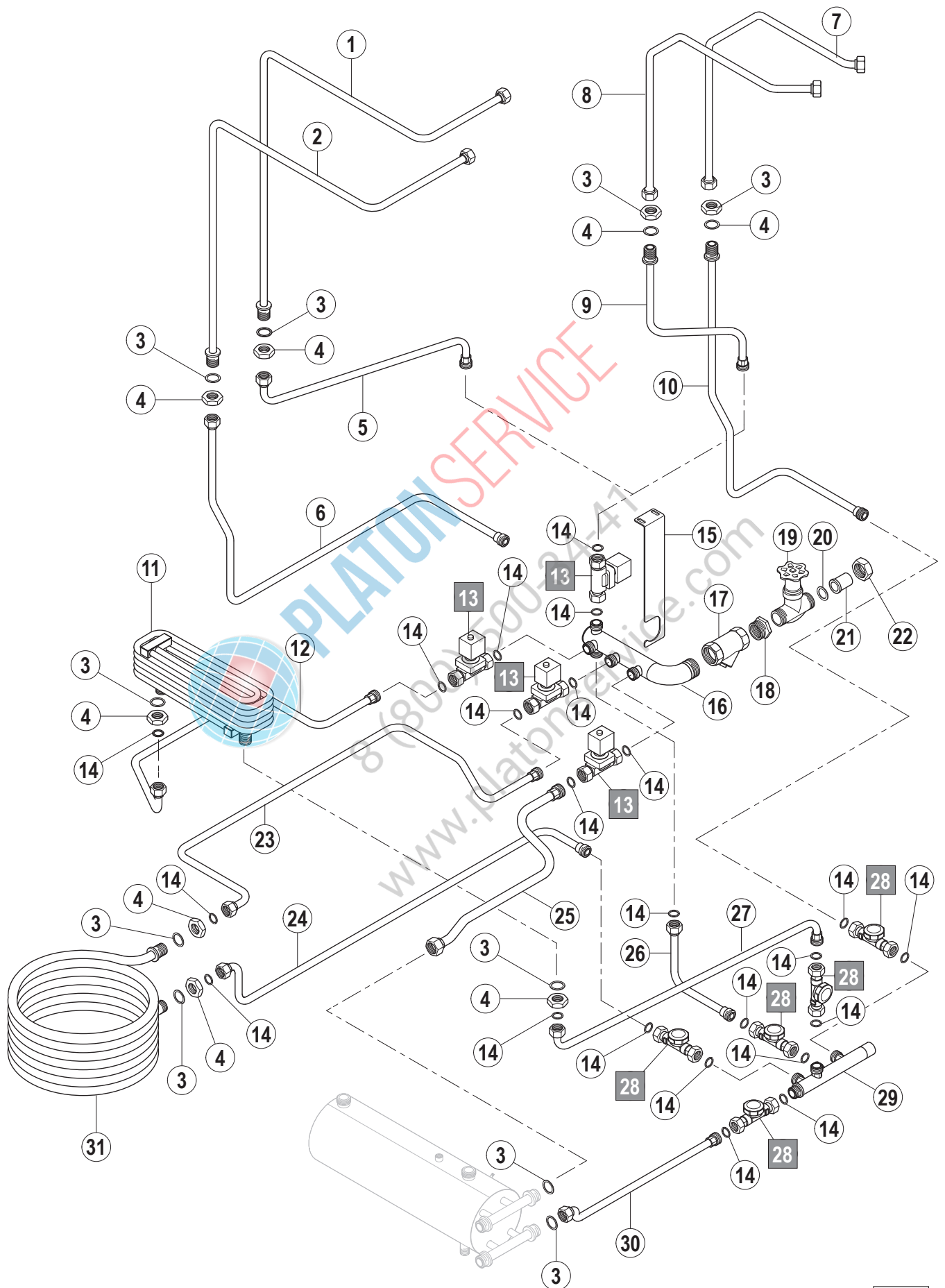

Pos.	A	B			X [mm]	Bemerkung / Remarks / Remarques
		CS	CN	CP		
01	L/R	---	01-291891-001	=		mit DS-Trocknung / with DS dryer / avec séchage DS
	R/L	---	01-291891-003	=		mit DS-Trocknung / with DS dryer / avec séchage DS
02	L/R	---	01-291891-002	=		mit DS-Trocknung / with DS dryer / avec séchage DS
	R/L	---	01-291891-004	=		mit DS-Trocknung / with DS dryer / avec séchage DS
03		---	00-304084-010	=		
04		---	00-609698-000	=		
05		---	01-291907-003	=		
06	L/R	---	01-291919-004	=		
	R/L	---	01-291932-004	=		
07	L/R	---	01-291897-001	=		mit CDC-Trocknung / with CDC dryer / avec séchage CDC
	R/L	---	01-291897-003	=		mit CDC-Trocknung / with CDC dryer / avec séchage CDC
08	L/R	---	01-291897-002	=		mit CDC-Trocknung / with CDC dryer / avec séchage CDC
	R/L	---	01-291897-004	=		mit CDC-Trocknung / with CDC dryer / avec séchage CDC
09		---	01-291907-004	=		
10	L/R	---	01-291919-003	=		
	R/L	---	01-291932-003	=		
11		---	---	01-291055-001		
12	L/R	---	---	01-291934-001		
	R/L	---	---	01-291934-002		
13		---	01-245593-001	=		Dampf / steam / vapeur 1 - 3,5 bar
		---	01-245593-002	=		Dampf / steam / vapeur <= 1 bar
14		---	00-302574-014	=		
15		---	01-291929-001	=		
16		---	01-291902-001	=		
17		---	00-774429-001	=		
18		---	00-609276-000	=		
19		---	00-165829-102	=		
20		---	00-300084-007	=		
21		---	00-846944-002	=		
22		---	00-609460-000	=		
23	L/R	---	01-291936-001	=		
	R/L	---	01-291936-002	=		
24	L/R	---	01-291917-003	=		
	R/L	---	01-291917-004	=		
25		---	01-291899-002	=		
26		---	01-291909-001	=		
27		---	---	01-291922-001		
28		---	01-245603-002	=		
29		---	01-291912-001	=		A-Maschine / A- machine
		---	01-291912-004	=		AA-Maschine / AA- machine
	L/R	---	---	01-291912-002		
	R/L	---	---	01-291912-003		
30		---	01-291915-002	=		
31		---	01-245647-002	=		

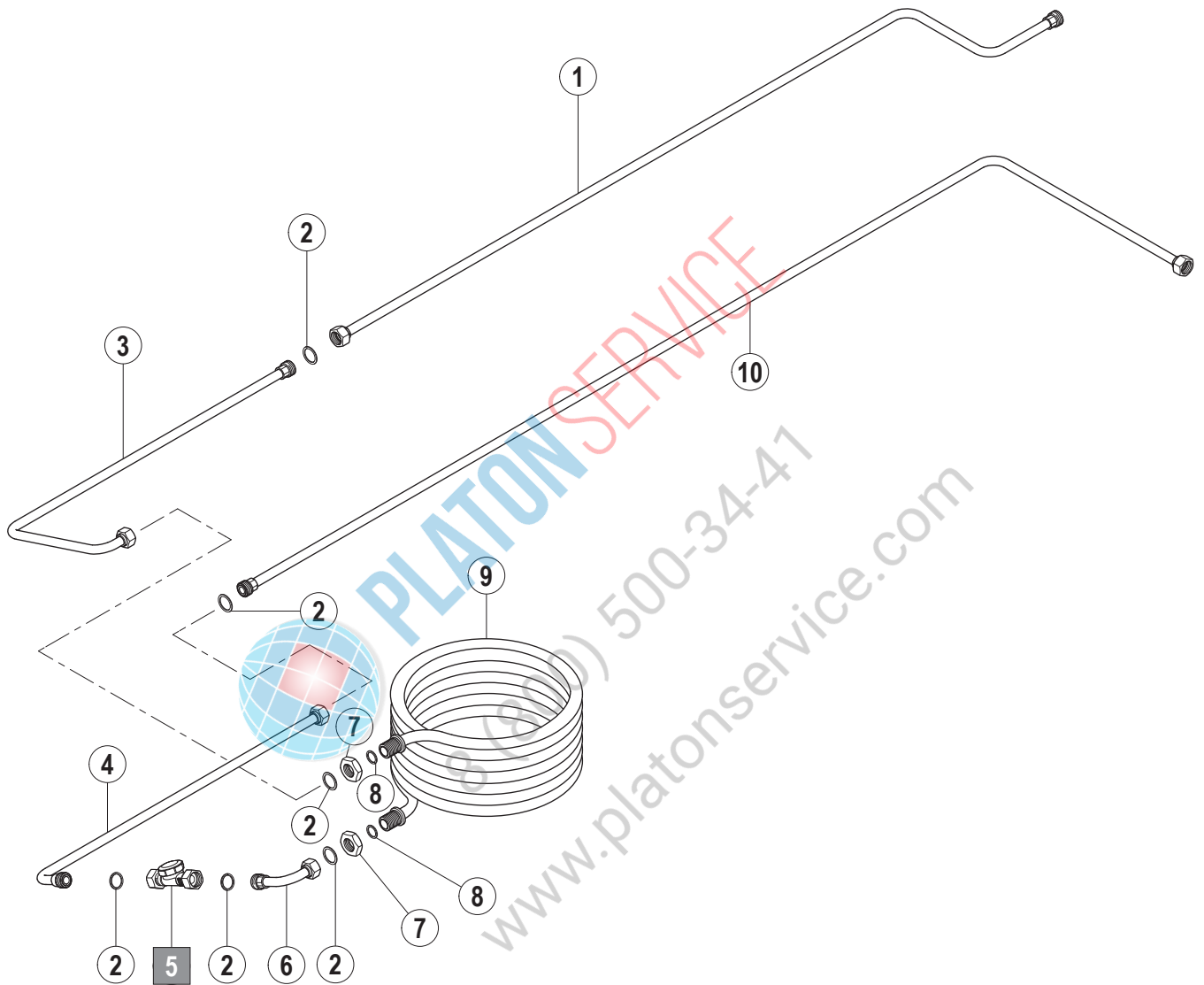

Pos.	A	B			X [mm]	Bemerkung / Remarks / Remarques
		CS	CN	CP		
01		---	01-291926-001	---		
02		---	00-302574-014	---		
03		---	01-291926-002	---		
04		---	01-291924-002	---		
05		---	01-245603-002	---		
06		---	01-291924-003	---		
07		---	00-609698-000	---		
08		---	00-300084-010	---		
09		---	01-245647-002	---		
10		---	01-291924-001	---		



PLATON SERVICE

8 (800) 500-34-41

www.platonservice.com



**PLATON**SERVICE

8 (800) 500-34-47

[www.platonservice.com](http://www.platonservice.com)



**PLATON**SERVICE

8 (800) 500-34-41

[www.platonservice.com](http://www.platonservice.com)

**CS / CN / CP**

**CAF Eckeinschub**

**CAF corner guiding**

**CAF guidage sur angle**

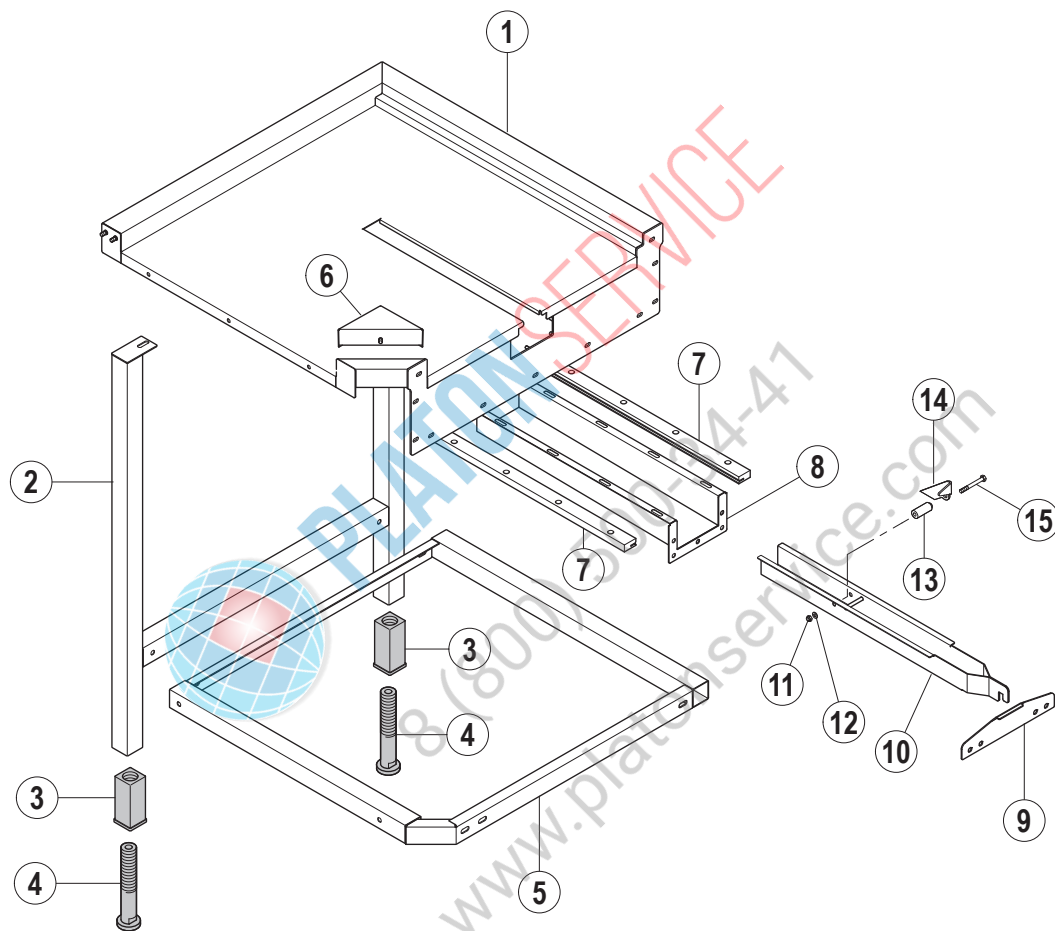





Laufrichtung  
**A** Working direction  
 Sens de marche

Maschinen-Grundtyp  
**B** Basic machine  
 Machine de base

Länge  
**X** Length  
 Longueur

Pos.	A	B			X [mm]	Bemerkung / Remarks / Remarques
		CS	CN	CP		
01	L/R	01-296079-001	=	=		
	R/L	01-296082-001	=	=		
02		00-896477-001	=	=		
03		00-325008-001	=	=		
04		00-325007-001	=	=		
05	L/R	00-896478-001	=	=		
	R/L	00-896478-002	=	=		
06		00-896362-001	=	=		
07		00-734945-001	=	=		
08		00-734947-001	=	=		
09		01-296076-001	=	=		
10		01-296078-001	=	=		
11		00-602502-000	=	=		
12		00-602286-000	=	=		
13		01-249194-001	=	=		
14	L/R	01-249191-001	=	=		
	R/L	01-249191-002	=	=		
15		00-603355-000	=	=		



PLATON SERVICE

8 (800) 500-34-41

www.platonservice.com





**PLATON**SERVICE

8 (800) 500-34-41

[www.platonservice.com](http://www.platonservice.com)

**CS / CN / CP**

**Tischenschalter**

**Table end switch**

**Interrupteur fin-de-course  
de table**

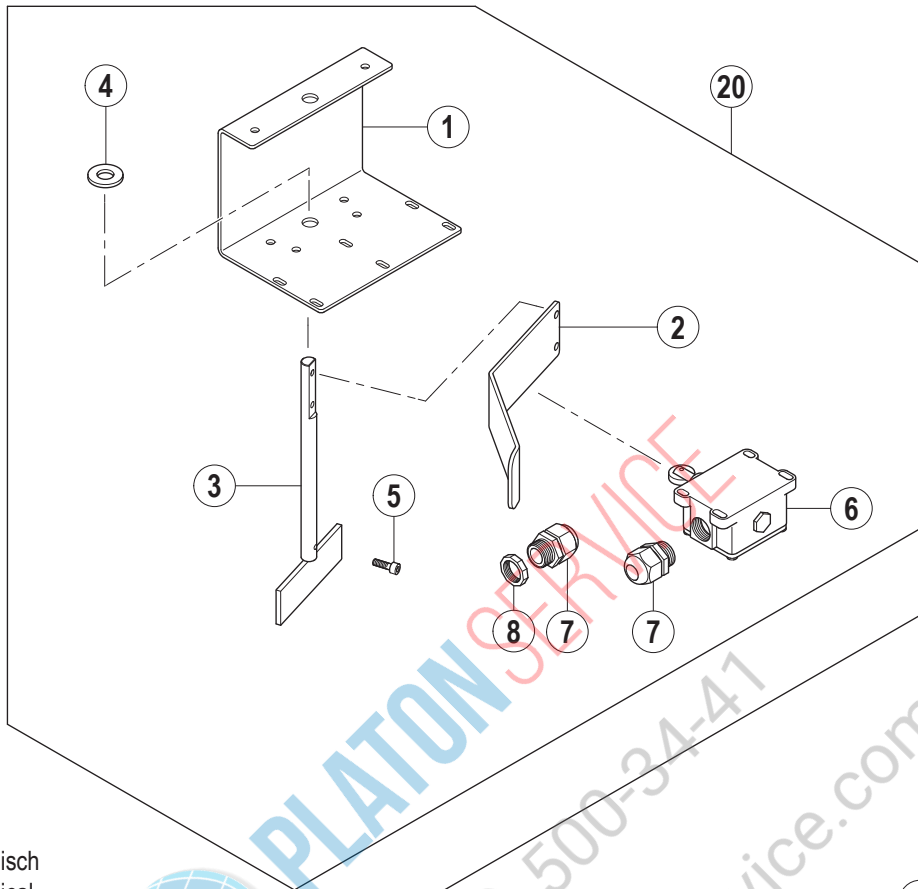

mechanisch  
mechanical  
mécanique

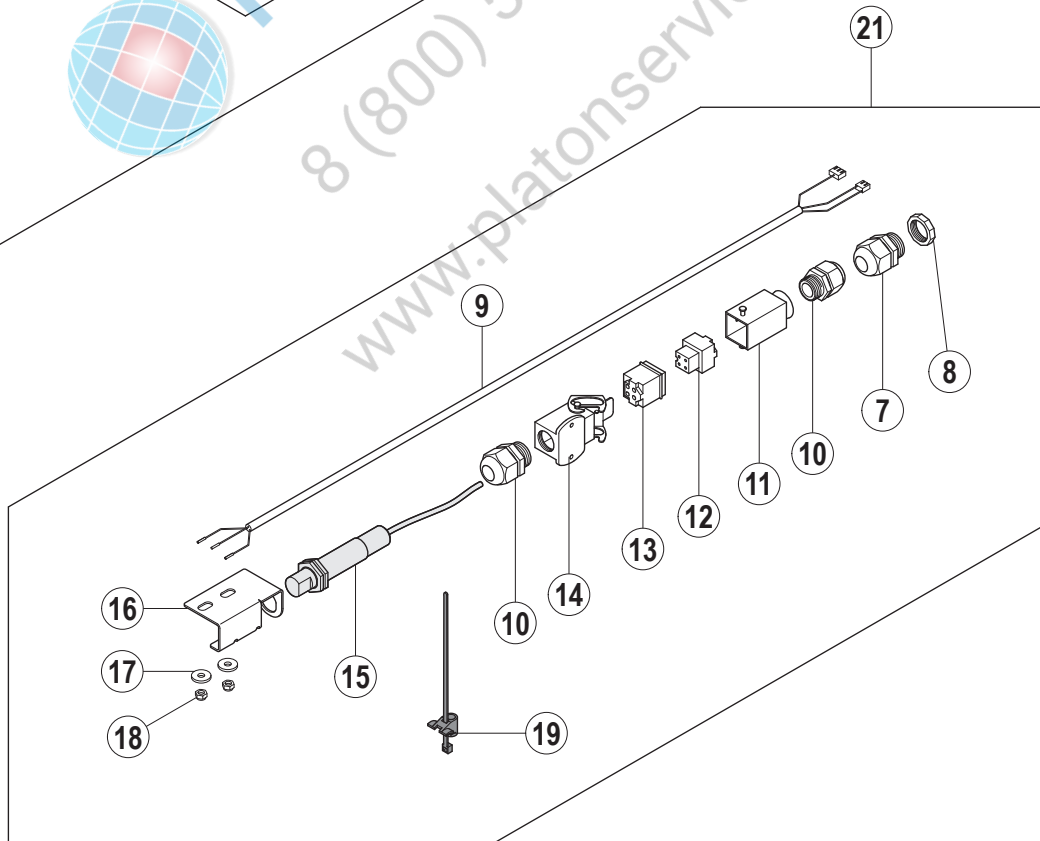

optisch  
optical  
optique



**A** Laufrichtung  
Working direction  
Sens de marche

**B** Maschinen-Grundtyp  
Basic machine  
Machine de base

**X** Länge  
Length  
Longueur

Pos.	A	B			X [mm]	Bemerkung / Remarks / Remarques
		CS	CN	CP		
01		00-896493-001	=	=		mit / with / avec 00-785410-001
		01-518205-001	=	=		mit / with / avec 00-785286-001
02		00-735084-001	=	=		
03		00-735085-003	=	=		
04		00-228694-014	=	=		
05		00-609472-000	=	=		
06		00-785410-001	=	=		siehe Schaltplan / see wiring diagram / voir schéma de câblage
		00-785286-001				siehe Schaltplan / see wiring diagram / voir schéma de câblage
07		00-695661-003	=	=		<b>M20</b>
08		00-695664-003	=	=		<b>M20</b>
09		00-691928-002	=	=		
10		00-324304-003	=	=		<b>PG11</b>
11		00-785090-003	=	=		
12		00-785090-004	=	=		
13		00-785090-005	=	=		
14		00-785090-001	=	=		
15		00-691927-001	=	=		
16		00-886535-001	=	=		
17		00-602318-000	=	=		
18		00-602501-000	=	=		
19		00-691923-001	=	=		
20		01-296170-001	=	=		mechanisch / mechanical / mécanique
		01-296170-004	=	=		mechanisch für Schwenktisch / mechanical for swing-aside table / mécanique pivoter table
21		01-296170-002	=	=		optisch / optical / optique
		01-296170-003	=	=		optisch für Schwenktisch / optical for swing-aside table / optique pivoter table





**PLATON** SERVICE

8 (800) 500-34-41

[www.platonservice.com](http://www.platonservice.com)

**CS / CN / CP**

**Vorhänge**

**Curtains**

**Rideaux**

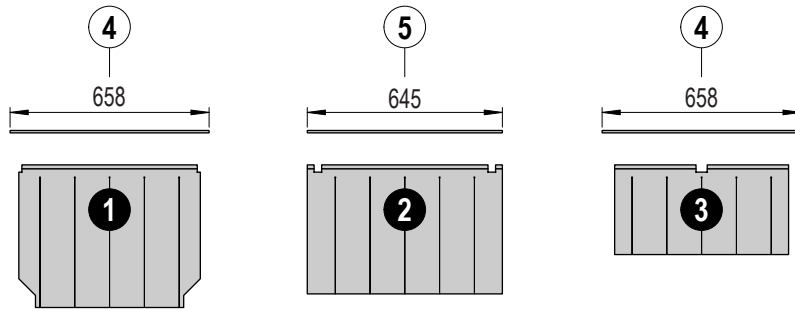

**Module / Modules**

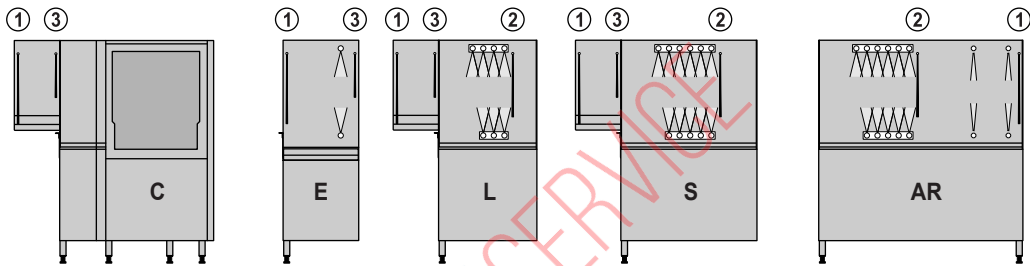

Beispiele / Exemples / Exemples

**CS**

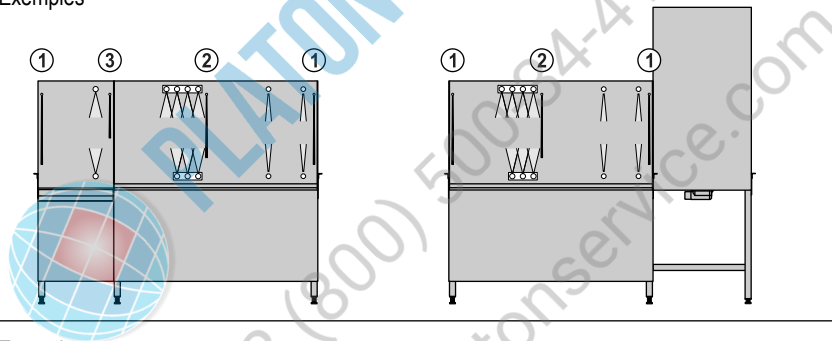

Beispiele / Exemples / Exemples

**CN**

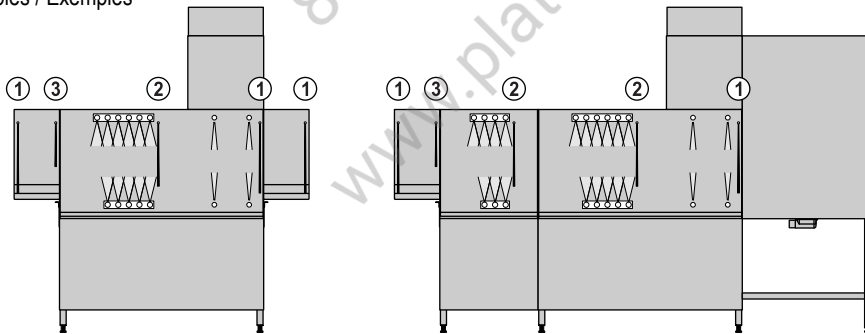

Beispiel / Example / Exemple

**CP**

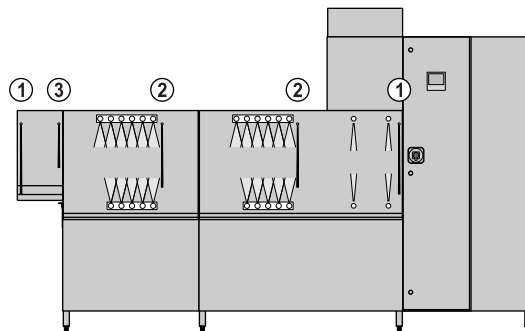



Pos.	A	B			X [mm]	Bemerkung / Remarks / Remarques
		CS	CN	CP		
01		01-291315-001	=	=		
02		01-291315-003	=	=		
03		01-291315-002	=	=		
04		01-245396-007	=	=		
05		01-245396-006	=	=		



PLATON SERVICE

8 (800) 500-34-47

www.platonservice.com



HOBART behält sich das Recht vor, an allen Produkten technische Änderungen und Verbesserungen ohne Ankündigung vorzunehmen.

As continued product improvement is a policy of HOBART, specifications are subject to change without notice.

Ce catalogue n'est pas contractuel. HOBART se réserve le droit, et sans préavis, d'apporter toutes modifications ou améliorations à ses matériels.